

UNIVERSAL

Instruction and Maintenance Manual

RADIOLOGICAL SURVEY METER
OCD ITEM NO. CD V-715, MODEL 1A

●
MANUFACTURED BY

LANDERS, FRARY & CLARK
NEW BRITAIN, CONN.

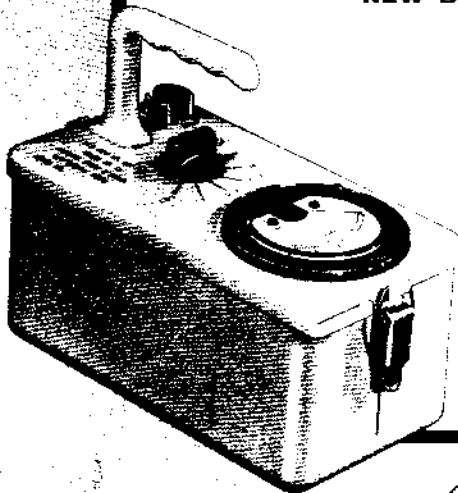

TABLE OF CONTENTS

SECTION 1.0 PRECAUTIONS

Paragraph	Page
1.1 High Impedance Circuitry..	3
1.2 Soldering Precautions.....	3
1.3 Continuity Testing.....	3

SECTION 2.0 GENERAL DESCRIPTION

2.1 Introduction.....	4
2.2 Ranges.....	4
2.3 Spectral Response.....	4
2.4 Accuracy.....	4
2.5 Controls.....	4
2.6 Circuit Check.....	4
2.7 Batteries.....	6
2.8 Meter.....	6
2.9 Physical Features.....	6

SECTION 3.0 THEORY OF OPERATION

3.1 Introduction.....	6
3.2 Ionization Chamber.....	6
3.3 Electrometer Tube.....	6
3.4 Measuring Circuit.....	7
3.5 Power Supply.....	7

SECTION 4.0 INSTALLATION

4.1 Installing the Batteries.....	8
-----------------------------------	---

SECTION 5.0 OPERATION

5.1 Operating the Unit the First Time.....	8
5.2 Reading the Instrument.....	8

SECTION 6.0 OPERATOR'S MAINTENANCE

6.1 Battery Replacement.....	8
------------------------------	---

SECTION 7.0 PREVENTIVE MAINTENANCE

7.1 Battery Life.....	10
7.2 Storage.....	10
7.3 Battery Inspection.....	10

SECTION 8.0 CORRECTIVE MAINTENANCE

8.1 Calibration.....	10
8.2 Disassembly for Corrective Maintenance....	10
8.3 In Case of Difficulty.....	11
8.4 Checking Power Supply....	11
8.5 Checking Electrometer Tube.....	11
8.6 Checking Ionization Chamber.....	11

SECTION 9.0 REPLACEMENT PARTS LIST

9.1 Electrical Components.....	14
9.2 Mechanical Components....	15
9.3 Vendors.....	16

LIST OF ILLUSTRATIONS

Figure	Title	Page
1.	Landers, Frary & Clark CD V-715 Survey Meter....	2
2.	Calibration Adjustment....	5
3.	Interior Details.....	9
4.	Printed Wiring Board and Component Location.....	12
5.	Schematic for CD V-715....	13

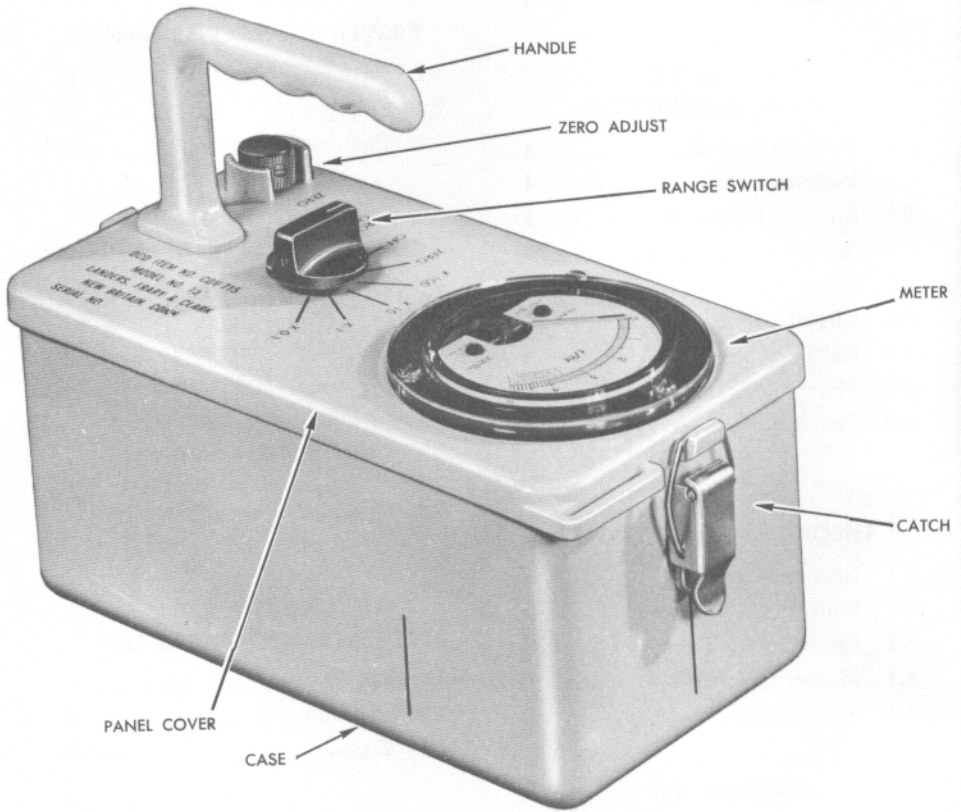

Fig. 1 — Landers, Frary & Clark CD V-715 Survey Meter

1.0 PRECAUTIONS

1.1 High Impedance Circuitry

The CD V-715 Survey Meter contains resistors having resistance values substantially higher than those normally encountered in electronic circuits. These high resistance values may be adversely affected by improper handling of the resistors themselves or of the associated circuit components. An accumulation of dirt or oils on these parts will permit the flow of leakage currents that will cause erroneous readings, especially on the X0.1 range. Therefore, it is essential that the high megohm grid resistors, the electrometer tube, the ceramic wafer of the range switch and the glass feed-thru of the ionization chamber be handled as little as possible. If contamination of these parts results from improper handling, they may be cleaned with alcohol applied with a soft brush. The alcohol should be the type that does not leave a residual film.

1.2 Soldering Precautions

The diodes and transistor used in the CD V-715 may be damaged by excessive heat during soldering maintenance operations. Where possible, the use of a heat-sink, such as long nose pliers applied to the lead wires, during soldering will aid in reducing the heat transmitted to the component. In addition, the soldering should be accomplished in a minimum amount of time.

1.3 Continuity Testing

In the event that it becomes necessary to test the electrometer tube and the meter movement for continuity, it is necessary to use an ohmmeter which has an output current of less than ten (10) milliamperes when used to measure resistances of about 150 ohms in the case of the electrometer tube. Similarly, the ohmmeter should produce less than fifty (50) microamperes when used to measure approximately 1800 ohms in the case of the meter movement; an external resistor might be used to meet this requirement.

2.0 GENERAL DESCRIPTION

2.1 Introduction

The Landers, Frary & Clark CD V-715 is a portable, battery powered transistorized survey meter using a plated steel, hermetically sealed ionization chamber as the detector. The chamber is mounted inside the case. The instrument and its accessories include a printed circuit board, indicating meter, ionization chamber, carrying strap and strap fastener. The case is watertight to withstand immersion. (See Fig. 1.)

2.2 Ranges

Four ranges are provided, 0-.5, 0-5, 0-50 and 0-500 R/HR. On the lowest range, the smallest division on the scale is .01 R/HR. Intensities higher than 500 R/HR are indicated by the meter reading off scale. The instrument is not harmed by this.

2.3 Spectral Response

The error introduced by changes in energy level from .08 MEV (Million Electron Volts) to 1.2 MEV is less than 15%.

2.4 Accuracy

The accuracy of this instrument is plus or minus 20 percent of true dose rate in Cobalt 60 and or Cesium 137 gamma radiation fields incident normal to the bottom and normal to the front of the instrument. Accuracy is not affected by altitude, light or radio frequency radiations.

2.5 Controls

Two controls are provided (See Fig. 1). The Range Switch is used to turn on the instrument, check its proper functioning, and select the required range. The Zero Control is used to adjust the meter to zero each time before use.

2.6 Circuit Check

The proper functioning of the measuring circuit including the battery, may be checked by setting the range switch to Circuit Check and observing the meter reading. The limits of acceptable indication cover the top 30 percent of the scale. This is a reliable indication of the condition of the instrument.

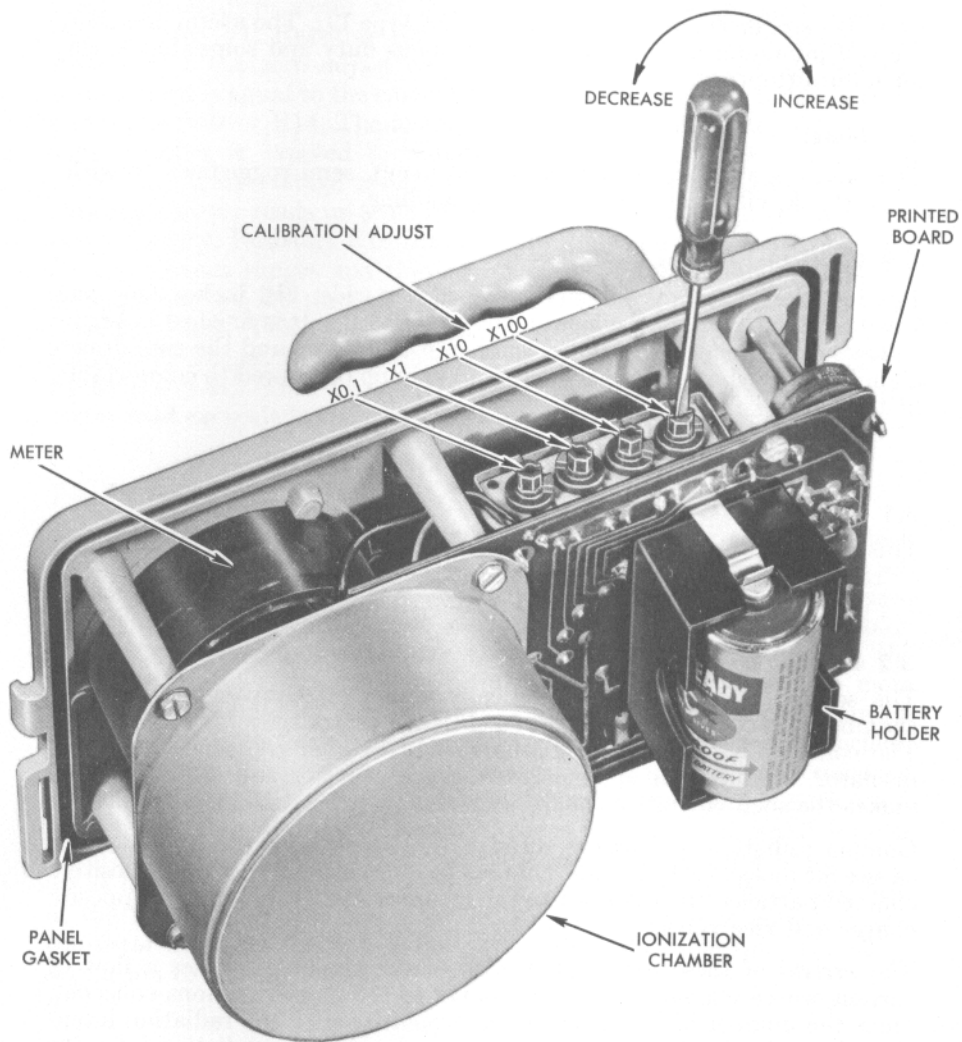

Fig. 2 — Calibration Adjustment

2.7 Batteries

One "D" size flashlight cell is used (NEDA type 13). The useful operating life is a minimum of 150 hour for continuous duty and somewhat longer for intermittent use.

2.8 Meter

The meter is a D'Arsonval type of movement, semi ruggedized to withstand shock, vibration and rough field handling.

2.9 Physical Features

The instrument is approximately $4\frac{1}{2}$ inches wide, $8\frac{1}{4}$ inches long and 7 inches high including the handle and weighs 4 lbs. It is finished in bright yellow baked enamel. The panel is die cast aluminum and the case drawn aluminum. The handle is also die cast aluminum contoured to comfortably fit the hand.

3.0 THEORY OF OPERATION

3.1 Introduction

This instrument consists of an ionization chamber, electrometer tube and a transistorized power supply. Intensity of radiation is indicated on a $3\frac{1}{2}$ inch panel meter. (See Fig. 1.)

3.2 Ionization Chamber

The sensing element is a hermetically sealed air equivalent ionization chamber. This chamber consists of a shell and center collector or electrode. The collector is insulated from the shell by a high resistance feed thru insulator. A voltage is applied between the collector and the shell. This makes the shell 60 volts negative with respect to electrical common.

Gamma radiation, in passing through the air contained in the chamber causes air molecules to become charged or ionized. Positive ions or positive charged particles are attracted to the chamber shell which has an opposite charge and vice versa.

The arrival of these ions at the shell of the chamber, causes a flow of current whose magnitude is proportional to the number of ions collected. Since the number of ions collected is proportional to the radiation intensity, the ionization current must be proportional to the radiation intensity at the ionization chamber.

3.3 Electrometer Tube

The very small ionization current from the chamber collector at .5 R/HR flows through a high ohmage resistor (2×10^{11} ohms) and develops a measurable voltage across the resistor. This voltage is also applied to the grid of V1 5886 Electrometer Tube which is connected as a triode. The filament of this tube is heated by the $1\frac{1}{2}$ volt "D" Cell. The flow of electrons from the heated filament is controlled by the voltage applied to the grid and also the voltage to the plate.

3.4 Measuring Circuit

A 50 microampere meter M1 is used to measure the change in current through tube V1. Resistors R3 and R4 act as bias resistors to bias V1. Resistor R1 the zero adjust control sets the plate voltage so that the tube current is equal to the current flowing in the meter due to the battery and series resistor R14. The meter M1 then reads zero. When the ionization chamber is exposed to radiation a negative voltage is developed across R6. This voltage results in a decrease in tube current and the indicating meter reads up scale by an amount proportional to the Radiation Intensity. Resistors R10 through R13 are calibrating potentiometers for the various ranges and they shunt some of the current around the meter. Resistors R6 through R9 are in series with the chamber on the various ranges. They act as voltage developing resistors for the four instrument ranges. R4 is switched out of the circuit in the check position by switch S-1C. This changes the bias on V1 and serves to make the meter read up scale in the check position.

3.5 Power Supply

The high voltage supply consists of a blocking oscillator circuit in which pulses are generated by a transistor, Q-1 alternately cut-off and saturated. The transformer windings between the base and collector are so phased that when the collector current starts to flow, the voltage at the base goes in the negative direction. By virtue of the base going negative, the collector current will increase still further causing the base to go more negative. The collector current increases until the transistor saturates. At this point, since there is no rate of change of current in the transformer, there is no signal induced in the base winding. When the signal is removed in the base circuit the collector current decreases and there is a resultant positive signal on the base. The transistor is cut off and a negative pulse is developed at the collector of the transistor. The transistor remains cut off as long as the positive signal on the base is present. When the field in the transformer core has collapsed, the base signal is gone and the transistor starts to conduct again and another full cycle from cut off to saturation to cut off follows.

The step-up turns ratio between the collector winding and the secondary winding produces voltage pulses which are then rectified by rectifiers CR1 and CR2.

Since the transformer is tapped, two voltages of opposite polarity appear. The turns ratio of T1 is such as make these voltages +8.5 volts and -60 volts. The +8.5 volts supplies plate voltage to the electrometer tube and the -60 volts fixes the operating level of the chamber. Capacitors C1 and C2 serve as capacitive filters for the two voltage supplies.

4.0 INSTALLATION

4.1 Installing the Battery

The instruments are shipped with the battery packed separately. To put the instrument into operation:

1. Open the case by releasing the catches at both ends, and remove the instrument from the case.
2. Remove the battery from its package, taking care not to drop it.
3. Place the "D" Cell in the battery holder positive end first. The housing is designed to assure correct polarity.

5.0 OPERATION

5.1 Operating the Unit the First Time

Turn the range switch to the Zero position, wait two minutes for the electrometer tube to warm up and adjust the Zero Control to bring the meter to zero.

Turn the range switch to the Check position. The meter should read within the red markings designated Circuit Check. If it does not, the battery may be low or trouble may exist in the circuit. (See Section 6 and 8 for maintenance procedures.) When the battery is new, the meter should read within the circuit check band. When the meter indicates below the bottom of the check band the battery should be replaced. Operators maintenance should be limited to replacement of the battery.

5.2 Reading the Instrument

Turn the range switch to the X-100, X-10, X-1 or X-0.1 range as required and read the radiation intensity on the meter. The meter readings must be multiplied by the factor for the range being used.

EXAMPLE:

A meter reading of 3.5 on the X-0.1 range indicates a radiation field of 0.1×3.5 or 0.35 R/HR. The indicator lines on the sides and front of the unit indicate the center line of the chamber.

6.0 OPERATOR'S MAINTENANCE

6.1 Battery Replacement

The battery should be replaced when the Circuit Check setting on the range switch makes the meter read below the low end of the circuit check band.

Remove the instrument from the case by opening two catches. Remove battery from holder and install battery as outlined in Section 4.

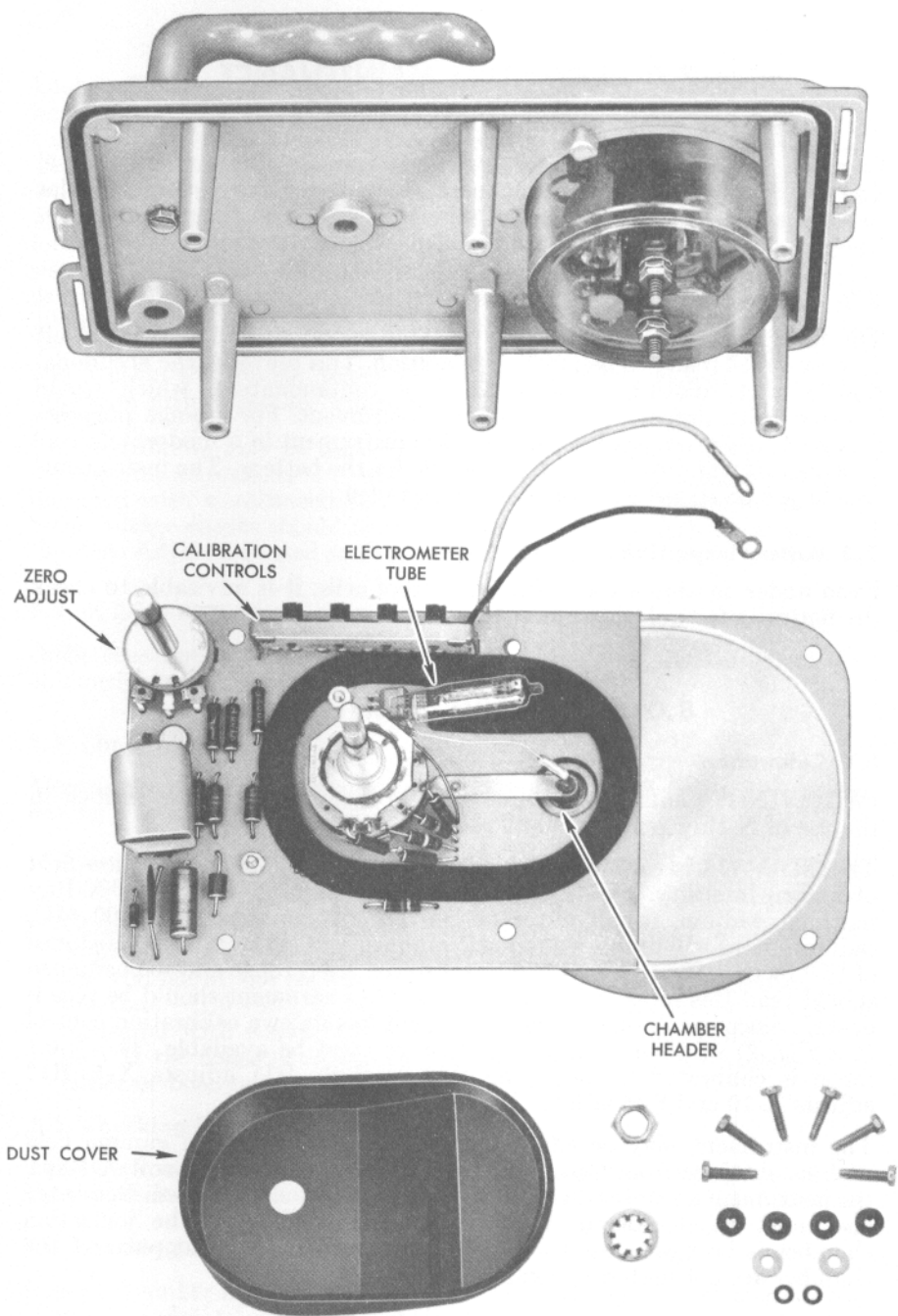

Fig. 3 — Interior Details

7.0 PREVENTIVE MAINTENANCE

7.1 Battery Life

Caution: Make certain the instrument is turned off when not in use. The Off Position places the index mark on the range switch perpendicular to the handle. The life of the battery is at least 150 hours under continuous use; for intermittent use the life is somewhat more.

7.2 Storage

The instruments are shipped in a packing container and should be left this way until ready to be put into operation. This prevents the accumulation of dirt, moisture, and radioactive contamination, which would interfere with proper operation of the instrument. For storage purposes it is best, wherever possible, to keep the instrument in a moderately cool area, as this will provide greater shelf life for the battery. The instruments should not be stored with the battery installed.

7.3 Battery Inspection

Even under continuous use with leak-proof cells, it is advisable to check the batteries for leakage at least once per month.

8.0 CORRECTIVE MAINTENANCE

8.1 Calibration

(WARNING: Calibration should only be done by personnel trained in the use of X-Ray generators and radioactive isotopes.)

The CD V-715 is calibrated by being placed in a gamma radiation field of known intensity. Fields of this type may be produced by an X-Ray machine, radium, cobalt 60 or cesium 137. As an example a 100 MC. radium source will produce a radiation intensity of .40 R/HR, at a distance of 17.9 inches. The CD V-715 when set to the X-0.1 range and so positioned should read this intensity. If it does not the instrument should be recalibrated. Since each range of the instrument has its own calibration control (See Fig. 2) suitable fields for each range must be available. The X-0.1 range is calibrated by adjusting R10, similarly R11 adjusts X-1, R12 adjusts X-10 and R13 adjusts X-100. (See Fig. 2 and 3.)

The instrument may be calibrated outside of its case if a gamma field such as obtained from Cesium 137 or Cobalt 60 is used. On soft X-Rays, the instrument should be in the case when calibration is checked. Geometry also must be considered. Errors may be introduced if the ionization chamber is brought close to the source of radiation so that parts of the chamber are not uniformly exposed to the radiation.

8.2 Disassembly for Corrective Maintenance

First remove instrument from case and remove battery. Remove the range knob and zero knob by loosening the set screws and pulling the

knobs off shafts. Loosen and remove 6 screws holding printed circuit board and chamber to the panel. Pull assembly free from panel being careful not to crack the printed circuit board or damage lead from chamber. The dust cover can be removed by loosening the hexagonal nut on the switch. This exposes all of the electronic components for servicing. (See Fig. 4.) Chamber may be separated from the assembly by pulling clip loose. The ionization chamber header, the ceramic switch section, resistors R6, R7, R8, R9 and the electrometer tube require special precautions. These components are all part of a very high resistance circuit. They should not be handled except for replacement. They should be touched only with clean tools and should be cleaned afterward with clean alcohol and a clean soft brush. Solder flux and fingerprints should be avoided, otherwise surface leakage will result.

Circuit troubles may be traced by reference to the circuit diagram Fig. 5. Voltage measurements are with respect to electrical common and are obtained with a voltmeter having a sensitivity of 20,000 ohms per volt. Such voltage checks should be made with the range switch set at zero and the Zero Adjust adjusted so that the meter reads zero.

8.3 In Case of Difficulty

Open case and make a visual inspection for shorts, broken wires, and obviously damaged or broken components.

8.4 Checking Power Supply

Measurements in the voltage supply should be made with a voltmeter having a sensitivity of 20,000 ohms per volt or higher.

1. Check the battery with the instrument turned on. The 1.5 volt supply should read at least 0.9 volt.
2. Check the voltages across C1 and C2, it should read approximately +8.5 volts and -60 volts respectively. If these voltages are low, check the voltage at the collector of transistor Q-1. This voltage should be less than -1.0 volts, with a fresh battery (1.5 volts) in the unit, when measured with respect to the emitter. If the voltage is high, replace Q-1. If the collector to emitter voltage is less than -1.0 volts, replace either or both rectifiers CR1 or CR2.

8.5 Checking Electrometer Tube

This check can best be accomplished by removing the battery and checking the resistance across the filaments. This should be less than 200 ohms.

8.6 Checking Ionization Chamber

Inspect chamber header for presence of dirt or solder flux. Measure resistance of header to outside of chamber. Resistance as measured on an ohmmeter capable of measuring 1000 megohms should be infinite. If ohmmeter indicates, the chamber is damaged. Care must be exercised in high humidity so as not to be misled by low resistance readings. The chamber should be checked in a dry environment.

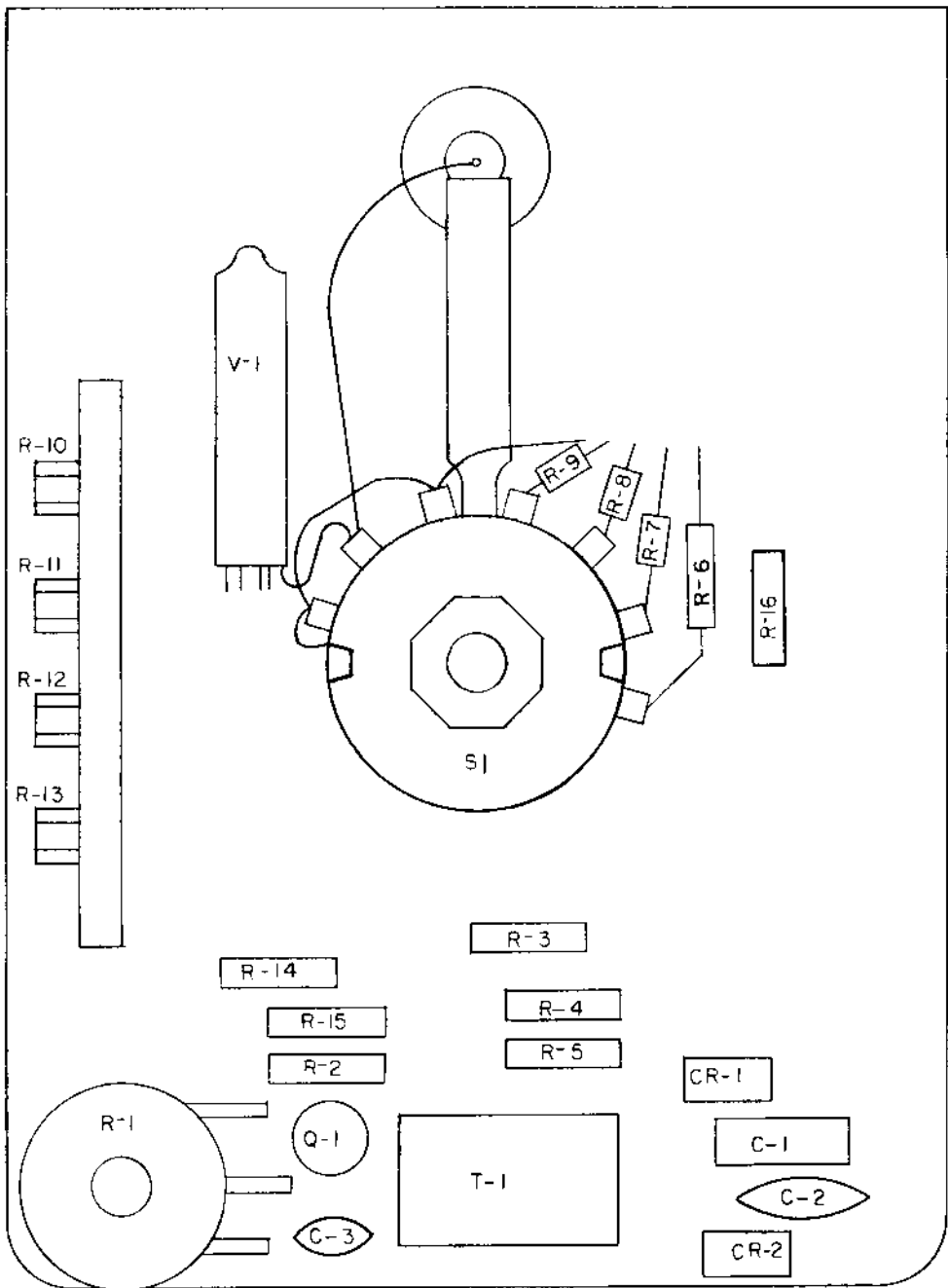

PRINTED WIRING BOARD (COMPONENT SIDE)

Fig. 4 — Printed Wiring Board and Component Location

RADIOLOGICAL SURVEY METER
 LANDERS FRARY & CLARK MODEL 66-2023
 SCHEMATIC DIAGRAM

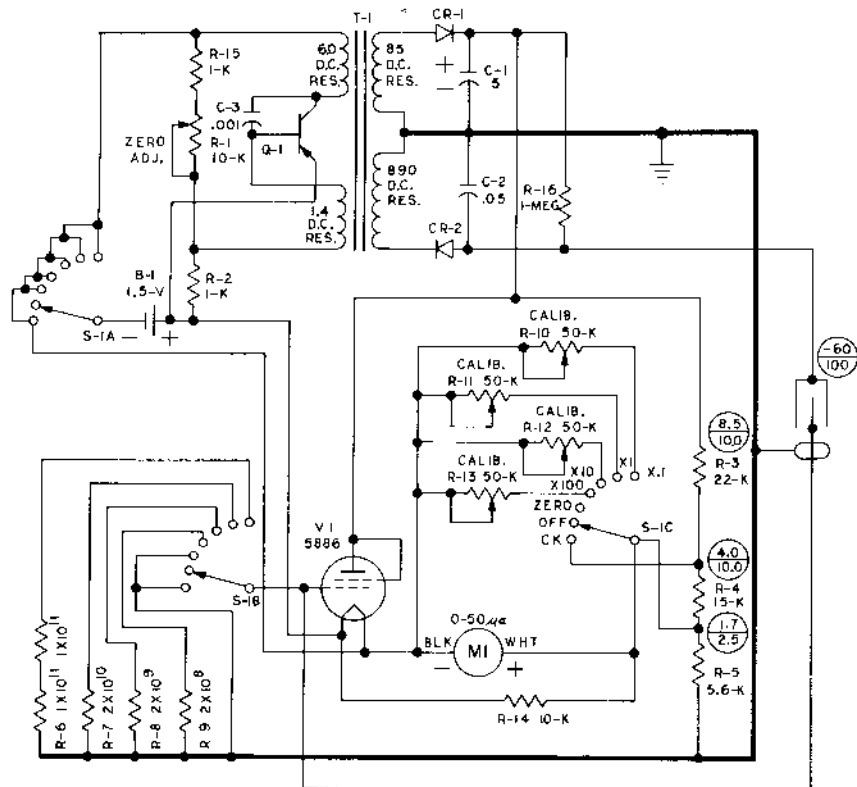

NOTES

1. ALL RESISTANCE VALUES IN OHMS
2. ALL CAPACITANCE VALUES IN MICRO-GRAMS
3. ALL TUBES ARE 9 PIN
4. ALL TIGHT MEASUREMENTS MADE USING A 275 K. OHM 250 VOLT 1/2 WATT
5. ALL MEASUREMENTS MADE WITH THE ELECTRICAL CONNECTIONS IN ZERO POSITION ON A VOLTAGE SCALE

Fig. 5 — Schematic for CD V-715

9.0 REPLACEMENT PARTS LIST

9.1 Electrical Components

Schematic Symbol	Quant. per Equip.	Description and Function	Supplier	Supplier's Part No.	LF&C Part No.	Rec. Spares for 5 Units
B1	1	Battery 'D' size 1½ Volt Supply Power	U.C.	950	66-2006-7701	15
C1	1	Capacitor, electrolytic 5 microfarad 25 volts, filter capacitor	E.C.I.	EN52	66-2023-085	1
C2	1	Capacitor, ceramic .05 microfarad 100 volts, filter capacitor	C.D.	H5	66-2023-107	1
C3	1	Capacitor, ceramic .001 microfarad, by-pass	AERO	MC1000	66-2023-086	1
CR1	1	Diode Rectifier—voltage rectifier 50 volts PIV	E.L.S.	E5269	66-2023-087	1
CR2	1	Diode Rectifier—voltage rectifier 100 volts PIV	B.T.	1194-5	66-2023-104	1
CH	1	Ionization Chamber, radiation detector	LF.&C.	66-2023-300	66-2023-300	1
M1	1	Meter, panel, 3½", 50 microamperes, indicates radiation intensity	P	PWB0150	66-2023-209	1
			G.M.	300S		
			W	715-248103		
Q1	1	Transistor, blocking oscillator	G.I.	1459	66-2023-088	1
R1	1	Potentiometer, 10k ohm, 30%, ¼W, Zero Adjust	C.	BA865-004	66-2023-078	1
R2, R15	2	Resistor, 1000 ohms, 10%, ½W, osc. reg.	M.N.	SLAK	66-2023-081	1
R3	1	Resistor, 22k, 5%, ½W, div., tube bias	M.N.	SLAK	66-2023-082	1
R4	1	Resistor, 15k, 5%, ½W, div., tube bias	M.N.	½W	66-2023-083	1
R5	1	Resistor, 5.6k, 5%, ½W, div., tube bias	M.N.	SLAK	66-2023-084	1
R6	2	Resistor, 1 x 10 ¹¹ ohms, 20%, ½W, signal res.	I.R.C.	GBT	66-2023-066	2
R7	1	Resistor, 2 x 10 ¹⁰ ohms, 20%, ½W, signal res.	I.R.C.	GBT	66-2023-067	1
R8	1	Resistor, 2 x 10 ⁹ ohms, 20%, ½W, signal res.	I.R.C.	GBT	66-2023-068	1
R9	1	Resistor, 2 x 10 ⁸ ohms, 20%, ½W, signal res.	I.R.C.	GBT	66-2023-069	1
R10, R11, R12, R13	1	Quadruple Variable Resistor, 50k ohms, 30%, ¼W, calibration adjust.	C.	1346146	66-2023-076	1
R14	1	Resistor, 10k ohms, 5%, ½W, meter current limit.	M.N.	SLAK	66-2023-079	1
R16	1	Resistor, 1 meg ohm, 10%, ½W, bleeder res.	M.N.	½W	66-2023-105	1
S1	1	Switch, rotary 2 deck 6 position, range switching	C.	PA082-001	66-2023-073	1
T1	1	Transformer, pulse step up	L.F.C.	66-2023-106	66-2023-106	1
TB	1	Printed Circuit Board	L.F.C.	66-2023-102	66-2023-102	1
V-1	1	Tube, electrometer, amplifies signal	P.A.	5886	66-2006-065	1
X1	1	Tube Socket	I.E.H.	SM4F	66-2023-075	1

9.2 Mechanical Components

Quant. per Equip.	Description and Function	Supplier	Supplier's Part No.	LF&C Part No.	Rec. Spares for 5 Units
2	Battery Contacts	L.F.&C.	66-2023-091	66-2023-091	2
1	Battery Holder	L.F.&C.	66-2023-063	66-2023-063	1
1	Case Assembly	L.F.&C.	66-2023-030	66-2023-030	1
1	Civil Defense Label	L.F.&C.	66-2006-019	66-2006-019	1
2	Gland, Water Seal—Seals Switch	L.F.&C.	66-2023-039	66-2023-039	2
1	Handle	L.F.&C.	66-2023-018	66-2023-018	1
1	Handle Gasket—Seals Handle	L.F.&C.	66-2023-203	66-2023-203	2
1	Knob, Pointer-rotate range switch	L.F.&C.	66-2006-014	66-2006-014	2
1	Knob, Zero-rotate zero adj.	L.F.&C.	66-2006-013	66-2006-013	2
1	Meter Gasket—seals meter	L.F.&C.	66-2023-206	66-2023-206	2
1	Panel Gasket—seals instrument	L.F.&C.	66-2023-202	66-2023-202	2
1	Panel, Top Cover	L.F.&C.	66-2023-201	66-2023-201	1
1	Schematic Label	L.F.&C.	66-2023-035	66-2023-035	1
2	Strap Fasteners	L.F.&C.	66-2023-010	66-2023-010	1
2	Strap Adjusters	L.F.&C.	66-2006-083	66-2006-083	1
1	Strap, Carrying	L.F.&C.	66-2006-087	66-2006-087	1
1	Switch Enclosure—covers electronic components	L.F.&C.	66-2023-062	66-2023-062	1
1	Switch Enclosure Gasket-seal	L.F.&C.	66-2023-074	66-2023-074	1

Symbol	Vendors	Address
E.C.I.	Electronics Comp. Importers	172 Walker Lane Englewood, New Jersey
C.D.	Cornell-Dubilier Electronics Inc.	50 Paris St. Newark, New Jersey
AERO	Aerovox Corporation	P.O. Box 68 Myrtle Beach, South Carolina
E.L.S.	Electronics Laboratory Supply	7208 Germantown Ave. Philadelphia 19, Pennsylvania
B.T.	Burns & Towne Inc.	871 Seventh Ave. New York 19, New York
G.M.	General Meters	P.O. Box 1701 Grand Junction, Colorado
G.I.	General Instrument Corp. Semi-Conductor Div.	600 West John St. Hicksville, Long Island, New York
I.E.H.	I.E.H. Mfg. Company	109 Prince St. New York, New York
M.N.	Molded National Composition Resistors	3133 East 12th St. Los Angeles, California
C.	Centralab	900 East Keefe Ave. Milwaukee 1, Wisconsin
L.F.&C.	Landers, Frary & Clark	47 Center St. New Britain, Connecticut
U.C.	Union Carbide	270 Park Ave. New York 17, New York
I.R.C.	International Resistance Company	401 N. Broad St. Philadelphia, Pennsylvania
P.A.	Price Associates	1387 Main St. Springfield, Massachusetts
P	Phaotron Inst. & Elec. Div.	151 Pasadena Ave. Pasadena, California
W	Weston Inst. Div.	614 Frelinghuysen Ave. Newark 14, N. J.