

Instruction Manual

FOR

RADIATION SURVEY METER

FCDA Item No. CD-V-710, Model No. 5

(VICTOREEN MODEL 710B)

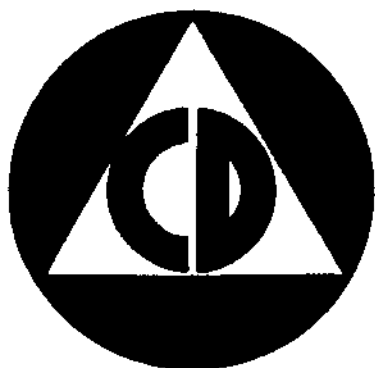

Part No. 710-97



The Victoreen Instrument Co.

5806 HOUGH AVENUE



CLEVELAND 3, OHIO

TABLE OF CONTENTS

Section 1		Section 5	
GENERAL DESCRIPTION		OPERATOR'S MAINTENANCE	
Paragraph	Page	Paragraph	Page
1.	Sensing Element 3	1.	Battery Replacement . . . 8
2.	Electronic Circuitry 3		
3.	Batteries 3		
4.	Meter and Controls 3		
5.	Physical Features 3		
Section 2		Section 6	
THEORY OF OPERATION		PREVENTIVE MAINTENANCE	
1.	Ionization Chamber 4	1.	Preventive Maintenance . . 9
2.	Input Circuit 5		
3.	Measuring Circuit 6		
Section 3		Section 7	
INSTALLATION		CORRECTIVE MAINTENANCE	
1.	Inspection 6	1.	Calibration 9
2.	Battery Installation 6	2.	Disassembly for Cor- rective Maintenance . . . 9
3.	Shoulder Strap Installation 6	3.	Trouble Shooting . . . 11
			Trouble Shooting Chart 11
Section 4		Section 8	
OPERATION		REPLACEABLE PARTS LIST	
1.	Zero Adjustment 7	1.	Electrical Components . . 14
2.	Circuit Check 7	2.	Mechanical Components 15
3.	Range Selection and Reading 8	3.	Maintenance Supply Parts 16
		4.	Names and Address of Manufacturers 16

LIST OF ILLUSTRATIONS

Figure	Title	Page
1.	CD V-710, Model 3, With Case Opened	4
2.	Simplified Schematic Diagram	5
3.	Method of Attaching Shoulder Straps	7
4.	Interior Views of the Model CD V-710, Model 5	10
5.	Circuit Diagram	13



CD V-710, Model 5

Section 1

GENERAL DESCRIPTION

The CD V-710, Model 5, Victoreen Model 710B is a portable monitoring instrument for the measurement of gamma radiation dose rates as high as 50 roentgens per hour. It is designed to be used by radiological Civil Defense personnel in determining radioactive contamination levels that may result from an enemy attack or other nuclear disaster.

1. SENSING ELEMENT.

The detecting element in the CD V-710, Model 5, is a hermetically sealed ionization chamber. This chamber is located in the lower front portion of the instrument as shown in Figure 1 to make the instrument equally sensitive to radiation from the bottom, front and both sides. The plastic lined, steel chamber has a wall thick enough to make the instrument insensitive to fission product beta particles. It is hermetically sealed to eliminate changes in sensitivity due to altitude air pressure, temperature changes and moisture effects. The chamber is replaceable without disturbing the calibration of the instrument.

2. ELECTRONIC CIRCUITRY.

A gasketed aluminum circuit plate located above the ion chamber, houses all of the electrical components and all of the wiring of the instrument. This circuitry serves to measure the minute current from the ionization chamber which indicates the presence of gamma radiation.

The gasketing serves to eliminate any possible moisture effects in the high resistance portions of the circuitry.

3. BATTERIES.

The CD V-710, Model 5, is powered by two "D" size flashlight cells (NEDA 13) and a 22½ volt miniature hearing-aid battery (NEDA 215). The batteries will operate the instrument continuously within specified accuracy limits for over 200 hours and much longer on an intermittent basis. The battery contacts and holders are fastened to the circuit plate as shown in Figure 1 to make a simple, rugged and unified circuitry.

4. METER AND CONTROLS.

The CD V-710, Model 5, uses a ruggedized, sealed meter to meet the instrument requirements for water tightness, shock and vibration resistance. Two controls are provided. One is a range switch which turns the instrument on, checks its operation and serves to select the proper range. The second is a "ZERO ADJUST" Control which is used to adjust the instrument to assure proper operation.

5. PHYSICAL FEATURES.

The instrument is housed in a tough, shock and scratch resistant plastic case molded of high-impact polystyrene. Carrying strap loops and "ZERO ADJUST" guard are permanently molded in. The nameplate and control knob information is indelibly molded into the case. Two toggle action spring clips serve to fasten the bottom half of the case to the top. The gasket, which is retained by the circuit plate, is fastened to the top half of the instrument

and provides a watertight seal when the instrument is closed. In order for this gasket to perform the function of providing a watertight seal, it is necessary that the gasket fit tightly against the case. To open the case, grasp the handle and the bottom half of the case and by applying a steady pull, the instrument will come apart. To close the case, carefully place the top onto the bottom, guiding the batteries into the molded cavities provided, then push one end of the case together by applying constant pressure and fasten the spring clip. The other end of the case can now be pushed together in the same manner. The instrument is approximately 8½" long, 4¾" wide and 4" high, excluding the handle. The instrument weighs three pounds and will float.

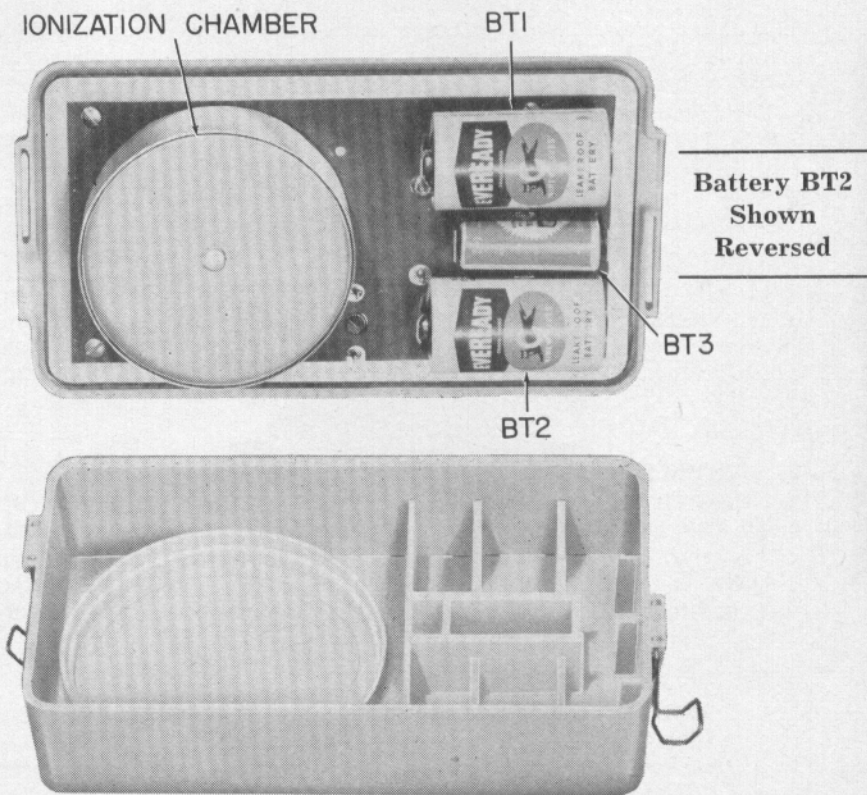

Figure 1. — The CD V-710, Model 5 With Case Opened

Section 2

THEORY OF OPERATION

1. IONIZATION CHAMBER.

The detecting element of the CD V-710, Model 5, is a hermetically sealed air equivalent ionization chamber. It consists of a conducting cylindrical container of plastic and steel called the shell and a thin conducting disk located

in the center of the shell, called the collector. The collector is insulated from the shell by an extremely high resistance feed-thru insulator. A voltage called the collecting voltage is applied between these two chamber electrodes. This makes the shell $22\frac{1}{2}$ volts positive with respect to the collector. See Figure 2.

Gamma radiation, in passing through the air contained in the chamber, causes air molecules to become charged or ionized. These charged particles or ions are attracted to the chamber electrode having the opposite charge, that is, positive ions move toward the collector of the chamber and vice versa. The arrival of these ions at the electrodes of the chamber constitutes a flow of current, the magnitude of which is proportional to the number of ions collected. Since the number of ions created is proportional to the dose rate, this ionization current is proportional to the dose rate at the ionization chamber.

The purpose of the electrical circuitry of the instrument is to amplify this current so that it may be read on a meter.

2. INPUT CIRCUIT.

The ionization current is extremely small—about .000005 microamperes at 0.5 r/hr which is full scale in the most sensitive range. It flows through a very high resistance (100,000 megohms) called a “Hi-Meg” connected to the collector of the ionization chamber as shown in Figure 2. This current flow

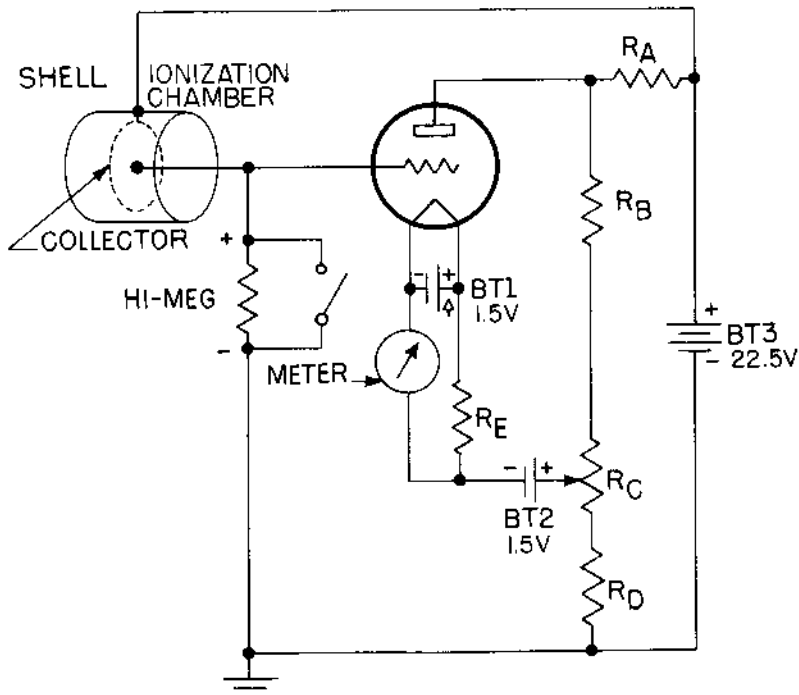

Figure 2. — Simplified Schematic Diagram

develops a voltage of about 0.5 volts at full scale across the "Hi-Meg" with the polarity shown.

The voltage developed is applied to the grid of a vacuum tube for amplification. Any of the minute ionization current flowing to the grid of the tube instead of through the "Hi-Meg" resistor would result in amplification of only a portion of the signal.

A special vacuum tube called an electrometer tube capable of amplifying voltages at extremely small grid currents is used to prevent this error. This tube is connected as a triode as shown in Figure 2.

3. MEASURING CIRCUIT.

Measurement of the grid voltage of the electrometer tube is accomplished by metering the change in plate current directly. The static plate current is cancelled by running a reverse current, supplied by the filament battery, BT1, thru the meter.

A "ZERO ADJUST" control is provided on the top cover of the instrument for balancing out static plate current. This balancing is accomplished by changing the grid bias on the electrometer tube by means of the potentiometer "Rc". In order to permit zeroing the instrument in a radiation field, a section of the range switch is used to short circuit the "Hi-Meg" resistor and prevent any ionization signal from being sensed by the input circuit on the "ZERO" range.

Battery "BT2" is incorporated to permit compensation of plate current changes that might occur due to a change in the voltage of "BT3". Sensitivity of the instrument is changed by switching "Hi-Meg" resistors. This is another function performed by the range switch.

Section 3 INSTALLATION

1. INSPECTION.

The instrument is shipped with batteries and carrying strap removed. Inspect the batteries for possible leakage before installation. Do not install leaking batteries. Inspect the instrument for damage in shipment. If damage is apparent the batteries should not be installed, thus preventing further damage due to possible short circuits.

2. BATTERY INSTALLATION.

Open the instrument by snapping open the two toggle clips at the end of the case and separate the two halves of the case. This exposes the battery holder and battery clips as shown in Figure 1. Insert the batteries in the appropriate clips as indicated on the battery label card. Observe battery polarity. Close the case by aligning the top and bottom halves carefully and squeeze the two halves of the instrument together firmly. Snap toggle clips closed.

3. SHOULDER STRAP INSTALLATION.

The carrying strap and two carrying strap buckles are packed separately. They are assembled to the molded-in carrying strap loops in the end of the case as shown in Figure 3, and length is adjusted to suit the operator.

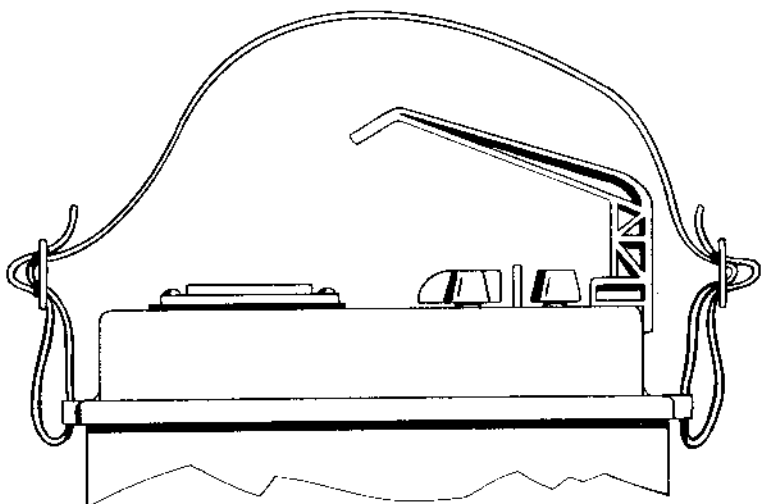

Figure 3. — Method of Attaching Shoulder Straps

Section 4 OPERATION

There are three simple basic steps recommended for proper operation of the CD V-710, Model 5. They are described as follows:

1. ZERO ADJUST.

Turn the instrument on by turning the range switch from "OFF" to the "ZERO" position. Wait about a minute to allow the electrometer tube to warm up, then orient the "ZERO ADJUST" control until the meter reads zero.

CAUTION

If the instrument is not zeroed properly, readings taken on any of the three ranges will be erroneous. The drift will be in an upscale direction at a very slow rate.

2. CIRCUIT CHECK.

Turn the range switch counter clockwise from the "ZERO" position through the "OFF" position to the "CIRCUIT CHECK" position. This position is spring-loaded to return to "OFF". The range switch must be held in this position for the circuit check. The meter should read in the red outlined section labeled "CIRCUIT CHECK". If it does not, either the batteries are low or trouble exists in the circuit. See Sections V and VII for proper procedures. Make certain the instrument is zeroed before making the circuit check.

Low or dead batteries are indicated by inability to "ZERO" the instrument or by a meter reading below the check band when the range switch is in the "CIRCUIT CHECK" position.

3. RANGE SELECTION AND READING.

Turn the range switch to the "X100", "X10" or "X1" range as necessary to obtain an upscale reading on the meter.

The meter reading observed must be multiplied by the factor indicated by the position of the range switch to obtain the radiation dose rate in roentgens per hour (r/hr).

EXAMPLE:	METER READING	0.38
	RANGE	"X100"
	INTENSITY OF RADIATION	38 r/hr

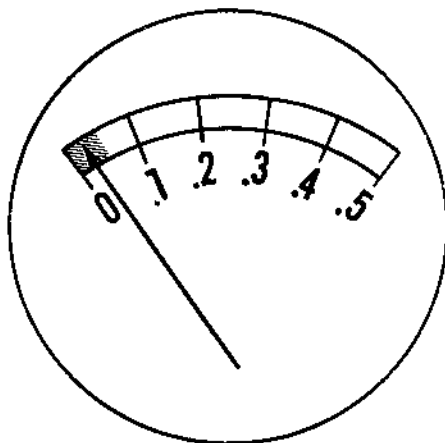

READINGS SHOULD NOT BE TAKEN WITH POINTER INDICATING IN LOWER 10% OF SCALE (SHADED IN ILLUSTRATION). TURN TO NEXT MOST SENSITIVE RANGE UNTIL POINTER INDICATES IN UPPER 90% OF SCALE (UNSHADED).

Another example is a meter reading of 0.24 on the "X10" range which shows a dose rate of 2.4 roentgens per hour while the same scale reading obtained with the instrument turned to the "X100" range corresponds to 24 roentgens per hour.

The "ZERO" or "CIRCUIT CHECK" may be performed at any time, whether or not the instrument is in a radiation field.

Section 5 OPERATOR'S MAINTENANCE

1. BATTERY REPLACEMENT.

Battery replacement is indicated whenever the instrument can no longer be zeroed or when the meter indicates below the "CIRCUIT CHECK" band. To replace the batteries, snap open the end clips and separate the two halves of the instrument. Remove all three batteries from their clips. Install new batteries as indicated in Section III, 2. Battery Installation. (If a voltmeter is available the individual batteries may be checked and replaced in accordance with Section VII, 3. Trouble Shooting.)

Section 6

PREVENTIVE MAINTENANCE

1. PREVENTIVE MAINTENANCE.

It is recommended that preventive maintenance procedures be carried out once a month when the instrument is in use, and about once every six months when the instrument is in storage.

Preventive maintenance should be carried out as follows:

- a. Remove the batteries, clean battery contacts and battery terminals, remove any corrosion present.
- b. Replace the batteries making certain that all batteries make good contact.
- c. Perform the operation indicated in Section IV, 1. ZERO ADJUST, and Section IV, 2. CIRCUIT CHECK.

Batteries should be removed from the instrument and stored separately if the instrument is to be stored more than a few weeks.

Section 7

CORRECTIVE MAINTENANCE

WARNING

Calibration should be attempted only by personnel trained in the use of radioactive isotope sources or X-ray generators.

1. CALIBRATION.

The CD V-710, Model 5, is calibrated by being placed in a gamma radiation field of known dose rate. Such fields are most commonly produced by using an X-ray machine or a radioactive material such as radium or Cobalt 60. As an example a 100 mc radium source will produce a dose rate of 0.40 r/hr at a distance of 18.1 inches. The CD V-710, Model 5, should read this dose rate when such a source is positioned from the center of the instrument's ion chamber. The center of the ion chamber is indicated by a molded-in vertical line on each side of the instrument case. If it does not, the instrument should be recalibrated. This is accomplished by removing it from its case and adjusting the "CAL" control on the circuit plate. The instrument may be recalibrated outside of its case in gamma fields from radium or Cobalt 60. On softer X-rays, the instrument should be in its case whenever calibration is checked. The distance from the center of the CD V-710, Model 5, ionization chamber to the calibrating source should be at least 12 inches to obtain reasonable geometry (reasonably uniform dose rate over the volume of the ionization chamber).

2. DISASSEMBLY FOR CORRECTIVE MAINTENANCE.

First remove the batteries from the CD V-710, Model 5. Open the circuit box by removing the four screws on the bottom of the circuit plate. Remove the knobs from the shafts on the top cover of the instrument. Press firmly on the top of the two exposed shafts, causing the circuit plate to be ejected from the instrument top. Remove the circuit shield, exposing the electronic components for any necessary repairs.

A view of the circuit plate is shown in Figure 4.

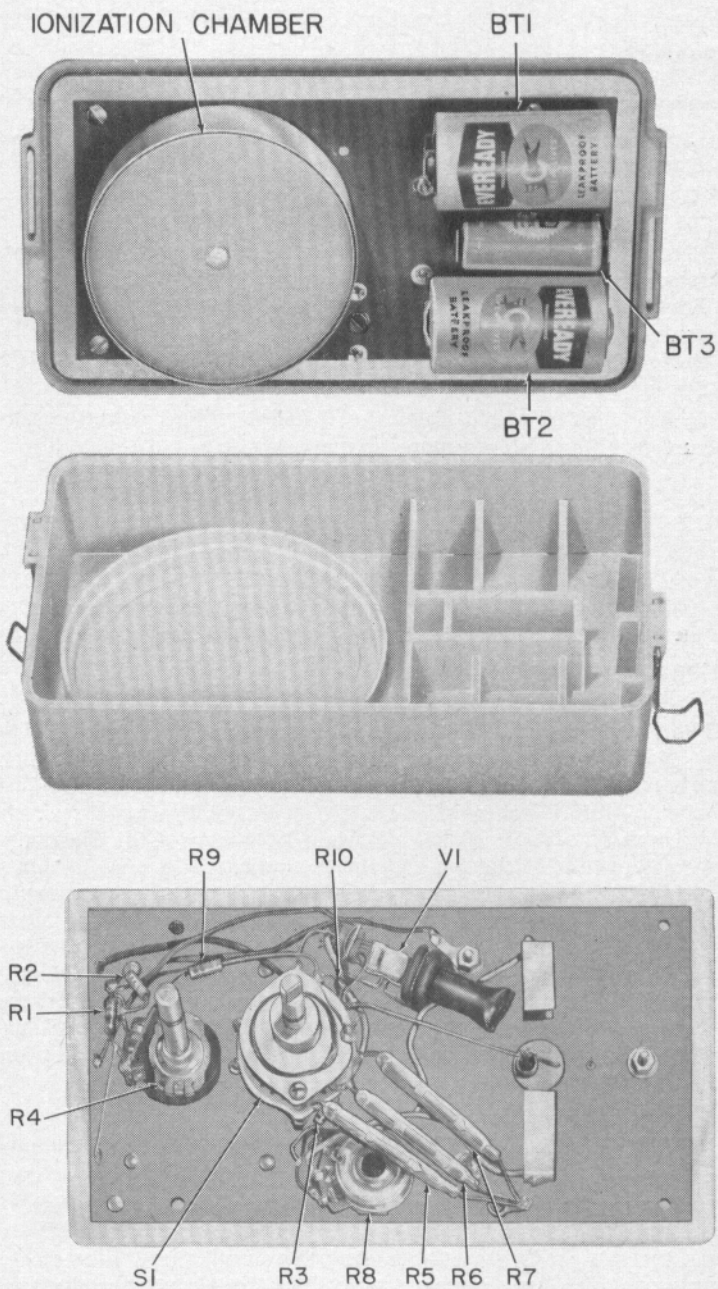

Figure 4. — Interior Views of the CD V-710, Model 5

3. TROUBLE SHOOTING.

The majority of the electrical components of the CD V-710, Model 5, are parts familiar to electronic technicians and are readily checked by conventional means. The electrometer tube, the "Hi-Meg" resistors, the ion chamber insulator and the ceramic switch section are the only components requiring special precautions. These components are all part of the high resistance input circuit. The insulating portions of these four components should not be handled. They should be touched only with clean tools when repairs are made. If surface leakage on any of these items is suspected, cleaning with pure alcohol using a clean camel hair brush is recommended. Avoid solder flux spattering on these components when repairs are made.

All batteries as well as the measuring circuit are checked by the "CIRCUIT CHECK". If trouble exists, batteries should be checked with any volt meter having a suitable range and a sensitivity of at least 1000 ohms per volt. The "D" cells should read higher than 1.2 volt and the "B" battery higher than 17 volts.

Circuit malfunctions may be traced with the aid of the schematic circuit diagram. Figure 5. Voltage measurements shown on this diagram are measured with respect to ground and are those obtained with a voltmeter having a sensitivity of 20,000 ohms per volt. Such voltage checks should be taken with the instrument turned to the "ZERO" range and with the "ZERO ADJUST" adjusted so that the instrument reads zero.

The following troubles and corrective action are presented as an aid to trouble shooting.

TROUBLE SHOOTING CHART

TROUBLE	CORRECTIVE ACTION
NO READING	
Low Batteries	Replace All Low Batteries
Corroded Battery Contacts	Inspect and Clean Battery Contacts
Calibration Control, Improperly Adjusted	Turn Calibration Control Clockwise and use "CIRCUIT CHECK" position to Test
Meter Damaged	Replace Meter
Chamber Damaged	Replace Chamber
Open Connection	Inspect All Solder Joints and Wiring
METER WILL NOT ZERO (reads upscale)	
Low Batteries	Replace All Low Batteries
Corroded Battery Contacts	Clean and Brighten All Battery Contacts

Electrometer Tube Filament Open	Remove Battery BTI. Set Range Switch to "OFF". Measure Resistance Between Battery Contacts. Should be Approximately 150 Ohms
Open Potentiometer	Check Potentiometers with Ohmmeter
Open Resistor	Check Resistors with Ohmmeter
Open Connection	Inspect All Solder Joints and Wiring
Open Switch Contact	Check Switch Contacts. Clean and if Necessary Adjust Contacts
Short Circuit	Inspect for Mechanical Damage

METER WILL NOT ZERO
(reads down-scale)

Defective Tube	Check Tube Filament
----------------	---------------------

INSTRUMENT READS LOW

Calibration Control Disturbed	Check Calibration as Outlined in Section VII, 1. Calibration
Faulty Electrometer Tube	Replace with New VX86 or 5386
Dirty High Resistance Components	Clean the "Hi-Meg" Resistors, Ceramic Switch Deck, Electrometer Tube and Chamber Insulator with Pure Alcohol
Chamber Leaks at High Altitudes because seal is broken	Locate and Repair Leak or Replace Chamber
Meter Damaged	Replace Meter

INSTRUMENT READS HIGH

Calibration Control Improperly Adjusted	Check Calibration as Outlined in Section VII, 1. Calibration
If High Reading on Only One Range, a Hi-Meg Resistor may be damaged	Replace All Three Hi-Meg Resistors with a matched set
Calibration Control Open	Check with Ohmmeter and Replace if Necessary

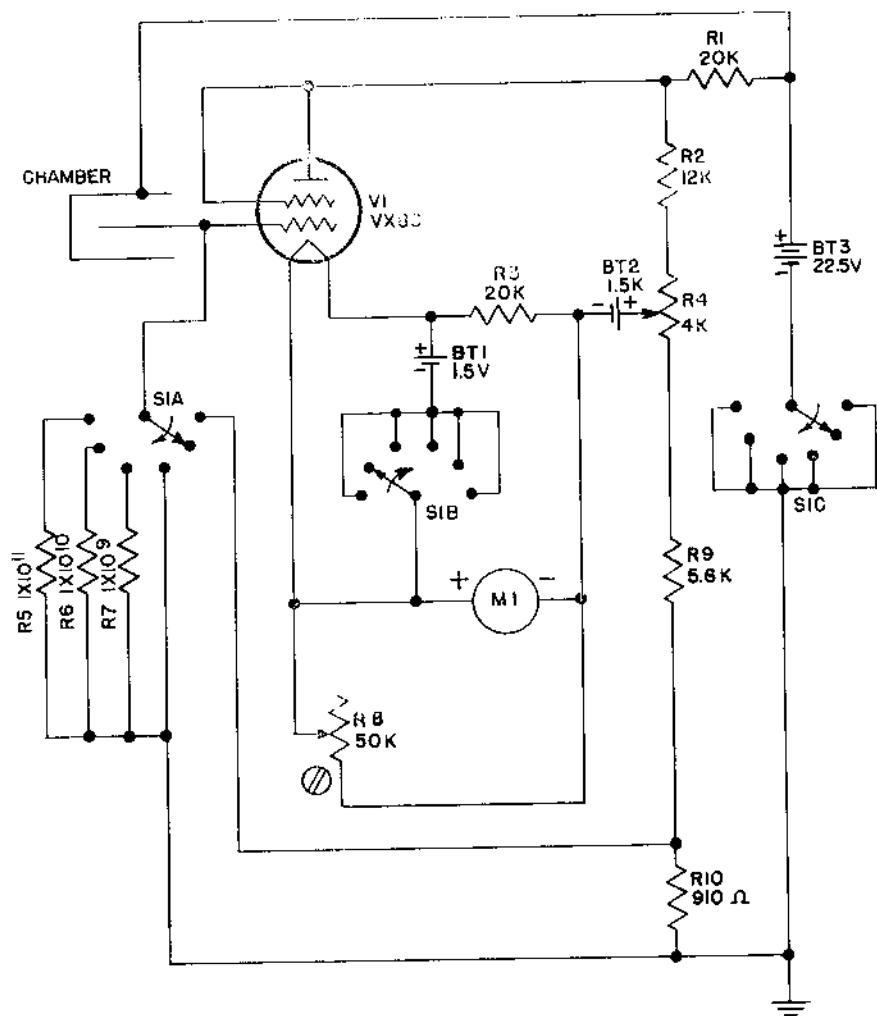

Figure 5. — Circuit Diagram

ELECTRICAL COMPONENTS

Circuit Symbol	Description	Function	Manufacturer	Mfg. Part No.	Victoreen Part No.
BT1, 2	Battery: 1.5 volt, "D" size flashlight	Filament	Nat'l Carbon	Eveready 950	263-17
BT3	Battery: 22½ volt, Min. hearing aid	Grid Bias	Nat'l Carbon	Eveready 412	356-38
M1	Meter: 0-20 ua	Indicating	Phaostron	_____	710-78
R1	Resistor: 20K ½ W ± 5%	Voltage Divider	IRC	_____	185-135
R2	Resistor: 12K ½ W ± 10%	Voltage Divider	IRC	_____	185-368
R3	Resistor: 20K ½ W ± 5%	Plate Current Bias	IRC	_____	185-135
R4	Potentiometer: 4K ± 20%	Zero Adjust	Centralab	_____	710-77
*R5	Resistor: Hi-Meg; 1 x 10 ¹¹ ohm	Grid Resistor Range X1	Victoreen	185-1034	185-1034
*R6	Resistor: Hi-Meg; 1 x 10 ¹⁰ ohm	Grid Resistor Range X10	Victoreen	185-1035	185-1035
°R7	Resistor: Hi-Meg; 1 x 10 ⁹ ohm	Grid Resistor Range X100	Victoreen	185-1036	185-1036
R8	Potentiometer: 50K ± 30%	Calibration Adjust	Stackpole	_____	710-41
R9	Resistor: 5.6K ½ W ± 10%	Voltage Divider	IRC	_____	185-274
R10	Resistor: 910 ohms ½ W ± 5%	Circuit Check	IRC	_____	185-622
S1A, B, C	Switch	Function Selector	Oak	_____	710-76
V1	Electrometer Tube	Elect. Amplifying Tube	Victoreen	VX86, 5886	720-58
			Raytheon	5886	
	Ionization Chamber Assembly	Detecting Element	Victoreen	710-104	710-104
	Tube Socket and Retaining Spring	Tube Connector	Elco	_____	720-40

*These resistors are matched in decade sets to ±2%.

Note: See Maintenance Supply Parts for Hi-Meg Color Code

MECHANICAL COMPONENTS

No. Req'd	Description & Function	Mfg. & No.	Victoreen No.
1	Case Top Assembly	Victoreen	710-105
1	Case Bottom Assembly	Victoreen	710-74
1	Switch	Oak	710-76
1	Range Switch Knob	Victoreen	710-85
1	Zero Control Knob	Victoreen	710-86
1	Meter Gasket	Victoreen	710-95
1	Case Gasket	Victoreen	710-94
1	Circuit Plate Assembly	Victoreen	710-107
1	Circuit Shield	Victoreen	720-44
2	Case Clips	Victoreen	720-36
2	Case Clip Retaining Ring	Victoreen	720-28
2	Carrying Strap Buckle	Waterbury No. 8075	710-44
1	Carrying Strap	Keller Products Co.	710-45
2	"O" Ring	Parker Appliance	710-42
1	Instruction Manual	Victoreen	710-97

MAINTENANCE SUPPLY PARTS

Suggested supply for five instruments for one year (400 hrs.) of operation.

Qty.	Circuit Symbol	Description	Victoreen Part No.
20	BT1, 2	"D" Cell Battery	263-17
10	BT3	22½ Volt Battery	356-38
1	V1	Electrometer Tube VX86 or 5886	720-58
1	M1	Meter	710-78
2	—	Carrying Strap	710-45
4	—	Carrying Strap Buckle	710-44
2	R5	Hi-Meg. 1 x 10 ¹¹ ohm (Red dot)	185-1034
2	R6	Hi-Meg. 1 x 10 ¹⁰ ohm (Yellow dot)	185-1035
2	R7	Hi-Meg. 1 x 10 ⁹ ohm (Orange dot)	185-1036
1	R4	Zero Potentiometer 4K	710-77
1	Ion Chamber	Ionization Chamber Assembly	710-104
1	—	Knob, Zero Control	710-86
1	—	Knob, Range Switch	710-85
1	S1A, B, C	Switch	710-76
1	—	Tube Socket and Retaining Spring	720-40

NAMES AND ADDRESSES OF MANUFACTURERS

<p>NATIONAL CARBON COMPANY 30 East 42 Street New York, N. Y.</p>	<p>OAK MANUFACTURING 1260 Clybourn Ave. Chicago, Ill.</p>
<p>VICTOREEN INSTRUMENT CO. 5806 Hough Ave. Cleveland, Ohio</p>	<p>CENTRALAB, INC. 900 Keefe Ave. Milwaukee, Wisconsin</p>
<p>STACKPOLE CARBON COMPANY St. Mary's Pennsylvania</p>	<p>PHAOSTRON 151 Pasadena Ave. Pasadena, California</p>
<p>PARKER APPLIANCE 3865 Carnegie Ave. Cleveland, Ohio</p>	<p>ELCO MANUFACTURING M Street below Erie Ave. Phila. 24, Pa.</p>
<p>WATERBURY Waterbury, Connecticut</p>	<p>RAYTHEON MANUFACTURING 55 Chapel Street Newton 58, Mass.</p>
<p>KELLER PRODUCTS 3099 Vine St. Cleveland, Ohio</p>	<p>I. R. E. 401 N. Broad St. Philadelphia, Pa.</p>