

Instruction and Maintenance Manual

RADIOLOGICAL SURVEY METER

OCD Item No. CD V-717, Model No. 1

Manufactured 1964



THE VICTOREEN INSTRUMENT COMPANY
5806 Hough Avenue • Cleveland 3, Ohio

TABLE OF CONTENTS

SECTION 1. PRECAUTIONS

Paragraph	Page
1.1 High Impedance Circuitry.....	3
1.2 Semi-Conductor Components..	3
1.3 Electrometer Tube.....	3

SECTION 2. GENERAL DESCRIPTION

2.1 Introduction	3
2.2 Sensing Element	3
2.3 Electronic Circuitry	4
2.4 Battery	4
2.5 Meter and Controls	4
2.6 Physical Features	4

SECTION 3. THEORY OF OPERATION

3.1 Ionization Chamber	4
3.2 Input Circuit	5
3.3 Measuring Circuit	5
3.4 Power Supply Circuit	5

SECTION 4. INSTALLATION

4.1 Inspection	6
4.2 Battery Installation	6
4.3 Shoulder Strap Installation	7

SECTION 5. OPERATION

Paragraph	Page
5.1 Adjustments and Readings	8
Step 1. Zero Adjust	8
Step 2. Circuit Check	8
Step 3. Range Selection and Reading	8
5.2 Remote Operation Using Cable Assembly	9

SECTION 6. OPERATOR'S MAINTENANCE

6.1 Battery Replacement	10
6.2 Cleaning	10

SECTION 7. PREVENTIVE MAINTENANCE

7.1 Preventive Maintenance	10
----------------------------------	----

SECTION 8. CORRECTIVE MAINTENANCE

8.1 Calibration	11
8.2 Disassembly for Corrective Maintenance	11
8.3 Preliminary Calibration Procedure After Replacing the Electrometer Tube or Transistor	12
8.4 Trouble Shooting	13

SECTION 9. PARTS LISTS

9.1 Electrical Components	18
9.2 Mechanical Components	19
9.3 List of Manufacturers	20

LIST OF ILLUSTRATIONS

Figure	Description	Page
1.	View of CD V-717, Showing Operating Controls and Case Sections	2
2.	Circuit Board Assembly and Battery Compartment	2
3.	Simplified Schematic Circuit Diagram	6
4.	View of Battery Compartment, Opened	7
5.	Method of Attaching Shoulder Straps	7
6.	Remote Operation Using Cable Assembly	9
7.	Range Calibration Adjustments	11
8.	Circuit Board Assembly	15
9.	Exploded View	16
10.	Schematic Circuit Diagram	17

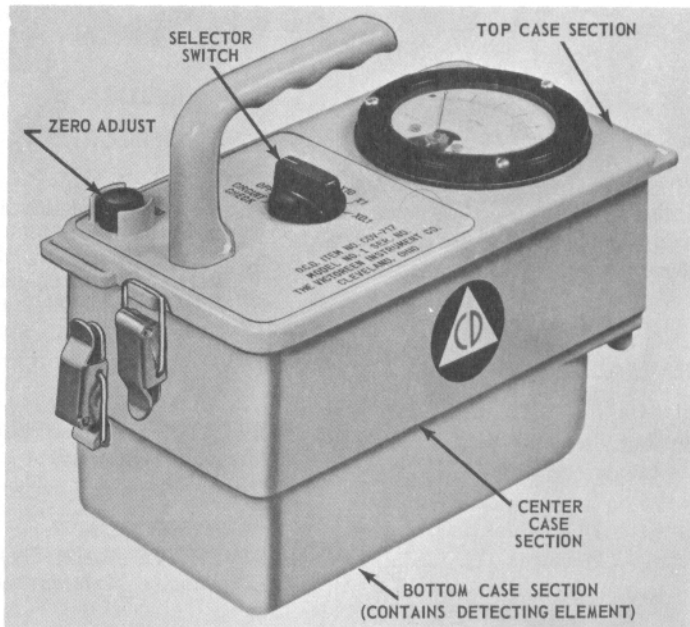

Figure 1. View of CD V-717, Showing Operating Controls and Case Sections

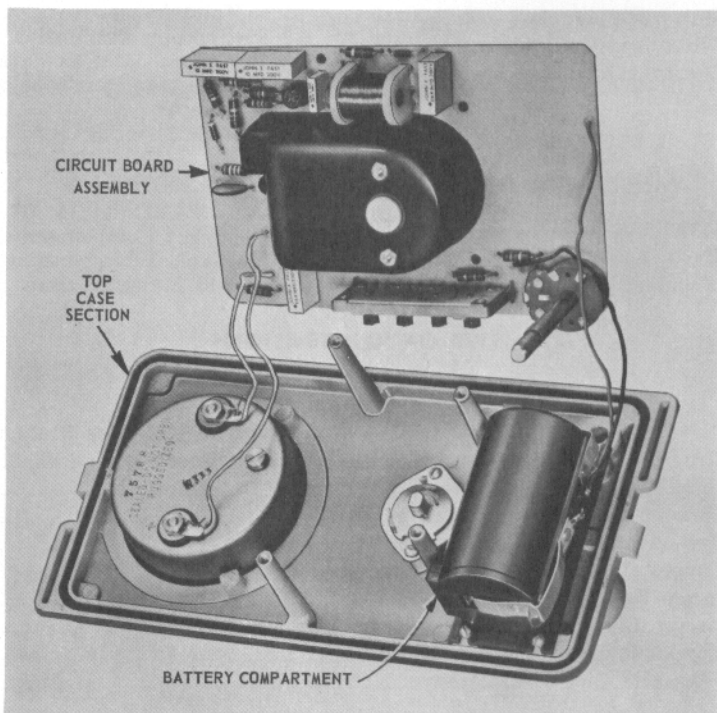

Figure 2. Circuit Board Assembly and Battery Compartment

1. PRECAUTIONS

1.1 HIGH IMPEDANCE CIRCUITRY:

The high megohm resistors, electrometer tube, ceramic switch-wafer, chamber connectors and bulkhead feed-thru, comprise the high impedance circuitry of the CD V-717. Any accumulation of dirt or grease on these parts will contribute to leakage currents that will cause upscale readings or lowered sensitivity which will be most evident on the X0.1 range. Therefore, it is desirable that these parts be handled as little as possible. These parts may be cleaned with a good quality solvent, such as alcohol, applied with a soft brush. The solvent should be free of any impurities or contaminants which might leave a residual film as the solvent evaporates. The entire instrument should be thoroughly dried by a low temperature bake-out (150°F or less) with the case open for one hour or dried with a desiccant.

1.2 SEMI-CONDUCTOR COMPONENTS (DIODES AND TRANSISTORS):

The semi-conductor components used in the CD V-717 may be damaged by prolonged exposure to excessive heat. When replacing any of these components the soldering operations should be accomplished as quickly as possible. Holding the lead between the component and the soldering point with a pair of pliers will decrease the heat transmitted to the component during the soldering operation.

1.3 ELECTROMETER TUBE:

When checking for a possible open filament of the electrometer tube, be certain to use an ohmmeter which has an output current of less than 10 milliamperes (ma). Current in excess of 10 ma may damage or even destroy the filament.

2. GENERAL DESCRIPTION

2.1 INTRODUCTION:

The Victoreen CD V-717, Model 1, portable monitoring instrument measures gamma radiation dose rates as high as 500 roentgens per hour (R/hr). It is designed to be used by radiological Civil Defense personnel in determining radioactive contamination levels that may result from an enemy attack or other nuclear disasters.

The CD V-717 consists of three case sections. The top section contains the meter and almost all of the circuit. The bottom section contains the ion chamber and provides for storage of the 25 feet of cable and the storage spool. The center section provides for electrically connecting the circuit board on the top section to the chamber from the bottom section. The case sections are electrically connected through two triaxial connectors which mate when the case sections are locked together. The instrument may be operated as a hand-held portable type survey instrument when all case sections are locked together, or, the bottom section of the case may be removed and the 25 foot triaxial cable employed to allow remote operation of the ion chamber detector. Instrument accuracy on each of its four ranges is within $\pm 20\%$ of the true dose rate from Cs¹³⁷ or Co⁶⁰ gamma radiation. This accuracy is maintained throughout a temperature range of -20°F to $+125^\circ\text{F}$, relative humidities to 100% and at altitudes from sea level to 25,000 feet. Use of the remote cable feature should give less than $\pm 5\%$ change in reading.

2.2 SENSING ELEMENT:

The detecting element in the CD V-717 is an hermetically sealed ionization chamber. This chamber is located in the front portion of the bottom case section of the instrument, as shown in Figure 6, to make the instrument nearly equally sensitive to radiation from the bottom and front. The ionization

chamber plus the instrument case will together total more than 1000 milligrams per square centimeter (mg/cm^2) in effective thickness to make the instrument insensitive to beta rays lower than 2 million electron volts (Mev) in energy. The ionization chamber is hermetically sealed to eliminate changes in sensitivity due to changes in air pressure resulting from altitude changes, temperature changes, and moisture effects. A 25 foot triaxial cable is stored on a removable spool directly behind the ion chamber to allow remote operation of the chamber from the instrument. Use of the cable increases the time required for similar response, but does not otherwise alter the instrument characteristics. The bottom section of the case housing the ion chamber is removed for remote operation.

2.3 ELECTRONIC CIRCUITRY:

All electrical components which make up the circuitry are fastened to a printed circuit board. The circuitry serves to measure the minute current from the ionization chamber which indicates the presence of ionizing radiation. The high impedance components are housed in a light-tight enclosure for protection and shielding. The circuit board and the battery are enclosed in the center case section. The triaxial bulkhead connector which connects the ion chamber to the rest of the high impedance circuitry is located on the center case section. Two cast pins project from the center case section to protect the connector from accidental damage.

2.4 BATTERY:

The CD V-717 is powered by one "D" size flashlight cell. The battery will operate the instrument continuously for over 150 hours and much longer on an intermittent basis.

2.5 METER AND CONTROLS:

The CD V-717 uses a ruggedized, sealed meter to meet the instrument requirements for water-tightness, shock and vibration resistance. Two operating controls are provided. One control is a selector switch which turns the instrument on, checks its operation and serves to select the proper range. The second is a zero control which is used to adjust the supply voltages to compensate for battery aging and temperature variation, thus, insuring rated accuracy for any readings taken.

2.6 PHYSICAL FEATURES:

The instrument is housed in a die cast aluminum three part case with a cast cantilever handle keyed and bolted in place. Carrying strap hooks and the zero control guard are permanently molded in. The nameplate and control knob information is indelibly engraved into the case top. Draw pull catches serve to fasten the three case sections together. Water-tightness is insured by closed cellular sponge rubber gaskets between the case sections. The instrument is operable with the case bottom removed. The battery is housed in a high-impact resistant plastic case which cannot be corroded by leaking battery fluids. However, metal parts may be corroded. The battery box is designed to be mechanically selective so that the battery cannot be inserted backwards. The instrument is approximately 9" long, 4½" wide and 7" high, excluding the handle. The instrument weight is 5¼ pounds and will float in water.

3. THEORY OF OPERATION

3.1 IONIZATION CHAMBER:

The detecting element of the CD V-717 is an hermetically sealed air filled ionization chamber. It consists of a conducting cylindrical container called the shell and a thin paper and aluminum disc called the collector, located in the center of the shell. The shell is the positive electrode and the collector the negative electrode. The collector is insulated from the shell by an extremely

high resistance feed-thru insulator. A voltage, called the collecting voltage, is applied between these two chamber electrodes. This makes the shell approximately 50 volts positive with respect to the collector. See Figure 3. Radiation, passing through the chamber, causes ionization of the air molecules contained within the chamber. These charged particles or ions are attracted to the chamber electrode having the opposite charge, i.e., positive ions move toward the center electrode of the chamber and negative ions move toward the shell.

The arrival of these ions at the chamber electrode constitutes a current which is proportional to the number of ions collected. Since the number of ions created is proportional to the radiation intensity, this ionization current is proportional to the radiation intensity in the ionization chamber.

3.2 INPUT CIRCUIT:

The ionization current is extremely small—about 6 micro-microamperes at 0.5 R/hr which is full scale on the most sensitive range. It flows through a very high resistance (180,000 megohms) high megohm resistor connected to the collector of the ionization chamber as shown in Figure 3. This ionization current develops a voltage drop of about 1.1 volts across the high megohm resistor with the polarity as shown.

The voltage developed is applied to the grid of a vacuum tube for amplification. Any of the minute ionization current flowing to the grid of the tube instead of through the high megohm resistor would result in amplification of only a portion of the signal. A special vacuum tube called an electrometer tube capable of amplifying voltages at extremely small grid currents is used to prevent this error. This tube is connected as a triode as shown in Figure 3.

3.3 MEASURING CIRCUIT:

In order to permit zeroing the instrument in a radiation field, a section of the selector switch is used to short circuit the high megohm resistor and prevent any ionization signal from being sensed by the input circuit on the "ZERO" position. A "ZERO" control is located on the top of the instrument for balancing out static plate current. This balancing is accomplished by changing electrometer tube voltages by means of the potentiometer, R2. The measurement of the grid voltage of the electrometer tube is accomplished by metering the change in plate current directly. The static plate current is cancelled by running a reverse current, supplied by the battery BT1, through the meter. The magnitude of this current is fixed by the bucking resistor R11.

Sensitivity of the instrument is changed by switching high megohm resistors, which is accomplished by the selector switch.

3.4 POWER SUPPLY CIRCUIT:

Three separate d.c. voltages are required by the measuring circuit as shown in Figure 3. These are the plate voltage supply of 10.5 volts, the grid bias supply of -3.8 volts and the ion chamber collecting voltage of 50 volts.

All of these voltages are obtained from a transistor oscillator circuit. The transistor Q1, driven by the battery BT1 through the lower portion of the primary of Transformer T1, constitutes this oscillator, with feed-back to the base of Q1 from the upper portion of the transformer via condenser C1 serving to sustain oscillation. The three output voltages are rectified from the a.c. output of the secondary of T1, by rectifiers CR1, CR2, and CR3, as shown.

Variations in output voltage with battery voltage and load current changes are prevented by the regulating network of R5 and R6. This network feeds back a portion of the plate supply voltage to the base of the transistor Q1 so as to control the bias current and hence, the battery current and magnitude of oscillation in such a fashion as to keep the plate voltage constant. This regulation method limits the battery drain through Q1 when the battery is new and is hence a method contributing to long battery life.

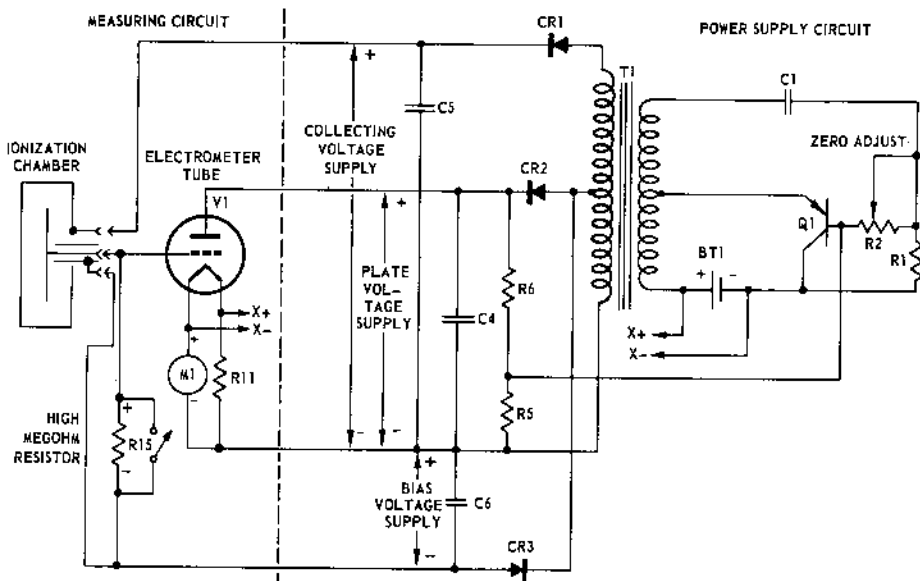

Figure 3. Simplified Schematic Circuit Diagram

4. INSTALLATION

4.1 INSPECTION:

The instrument is shipped with a battery and a carrying strap removed from the instrument and packed separately. Inspect the battery for possible leakage before installation. Do not install a leaking battery. Inspect the instrument for damage in shipment. If damage is apparent the battery should not be installed, thus preventing further damage due to possible short circuits.

4.2 BATTERY INSTALLATION:

Open the instrument by snapping open the draw pull catch at each end of the case top and separating the top from the center case section. Pull the case top straight up from the center case section, so as not to cause the circuit board to seize on the barrel of the feed-thru connector. It is important not to touch any of the high impedance circuitry, such as the bulkhead feed-thru connector, the cable connectors, and the ion chamber connection. This exposes the battery box as shown in Figure 4, insert the battery in the battery box observing the indicated polarity. (The battery box is designed to be mechanically selective so that the battery cannot be inserted with reversed polarity). Close the instrument by aligning the top and the center case sections and squeezing together gently. The center case section has two ribs cast into the sides which prevent reversing the top case section relative to the center case section. Make sure the two case sections are properly oriented and in the closed position before attempting to close the draw pull catches. Snap the draw pull catches closed.

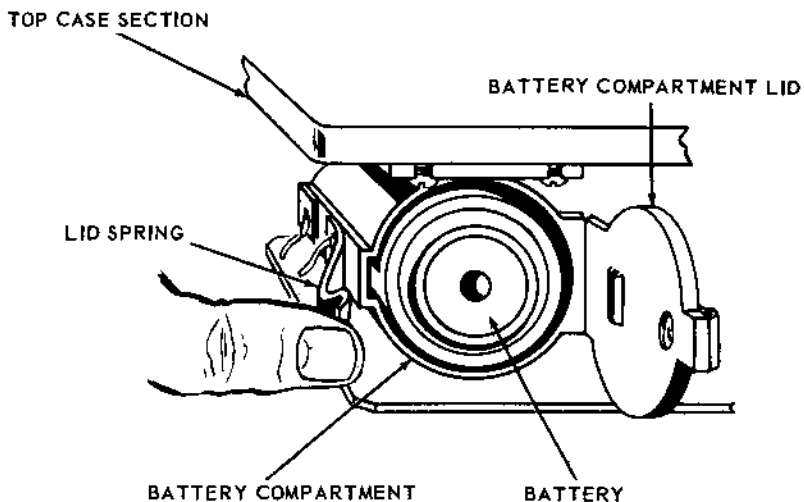

Figure 4. View of Battery Compartment Opened

4.3 SHOULDER STRAP INSTALLATION:

The carrying strap and two carrying strap slides and clips are packed separately. They are affixed to the cast-in carrying strap loops in the end of the case top section as shown in Figure 5, and the length is adjusted to suit the operator. The strap may or may not be used as desired by the monitor.

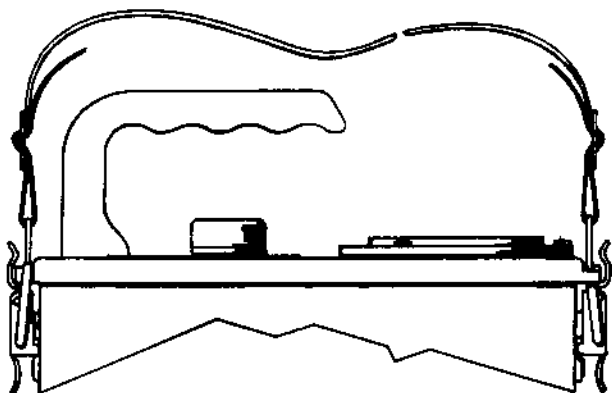

Figure 5. Method of Attaching Shoulder Straps

5. OPERATION

5.1 ADJUSTMENTS AND READINGS:

There are three simple basic steps recommended for proper operation of the CD V-717. They are described as follows:

Step 1. Zero Adjust

Turn the instrument on by turning the selector switch from "OFF" to the "ZERO" position. Wait about a minute to allow the electrometer tube to warm up, then adjust the "ZERO" control until the meter needle indicates zero on the meter.

CAUTION

If the instrument is not zeroed properly, readings taken on any of the four ranges will be erroneous.

Step 2. Circuit Check

Turn the selector switch counter clockwise from the "ZERO" position through the "OFF" position to the "CIRCUIT CHECK" position. This position is spring-loaded to return to "OFF". The selector switch must be held in this position for the circuit check. The meter should read in or above, the red outlined section labeled "CIRCUIT CHECK". If it does not, either the battery is low or trouble exists in the circuit. See Sections 6 and 8 for proper procedures. Make certain the instrument is zeroed before making the circuit check.

CAUTION

Even if the circuit check response is satisfactory, the instrument still may not respond to radiation properly; because, neither the ion chamber or its output signal being delivered to the grid of the electrometer tube is checked. Either (1) a defective ion chamber, (2) a break in the signal path, or (3) a dirty (leaky) connector will result in the instrument not properly measuring radiation or in some cases not provide any response to radiation.

A low or dead battery is indicated by inability to zero the instrument or by a meter reading below the check band when the selector switch is in the "CIRCUIT CHECK" position.

Step 3. Range Selection and Reading

Turn the selector switch to the "X100, X10, X1, or X0.1" range as necessary to obtain an upscale reading on the meter.

The meter reading observed must be multiplied by the factor indicated by the position of the selector switch to obtain the radiation dose rate in R/hr.

EXAMPLE:

METER READING	3.8
RANGE	X100'
<hr/>	
INTENSITY OF RADIATION	380 R/hr

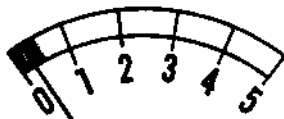

READINGS SHOULD NOT BE TAKEN WITH POINTER INDICATING IN LOWER 10% OF SCALE (SHADED IN ILLUSTRATION). TURN TO NEXT MOST SENSITIVE RANGE UNTIL POINTER INDICATES IN UPPER 90% OF SCALE (UNSHADED).

Another example is a meter reading of 2.4 on the "X10" range which indicates a dose rate of 24 R/hr while the same reading obtained with the instrument turned to the "X100" range corresponds to 240 R/hr.

It is recommended that the instrument be kept turned off, except for periods where frequent readings are required, in order to conserve battery life. The "ZERO" or "CIRCUIT CHECK" may be performed at any time, whether the instrument is in a radiation field or not.

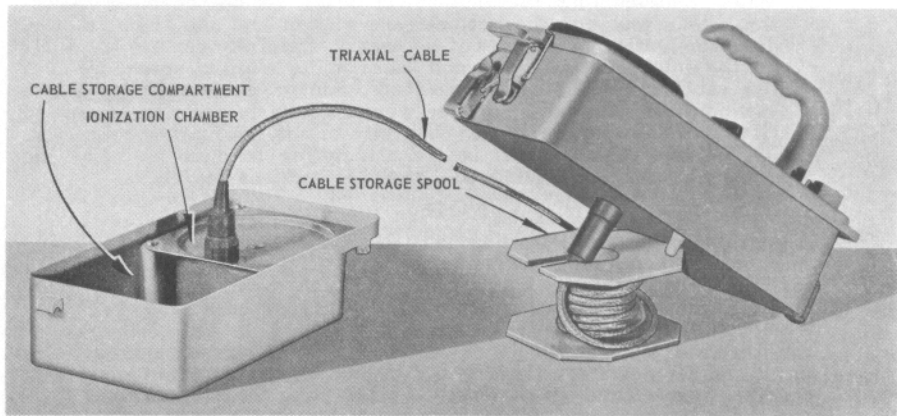

Figure 6. Remote Operation Using Cable Assembly

5.2 REMOTE OPERATION USING CABLE ASSEMBLY:

- a. Release the draw pull catches holding the bottom case section to the center case section, and separate the two case sections.
- b. Remove the cable from its stored position behind the ion chamber and carefully unwind it from the spool so as to avoid kinking and tangling it. Don't let cable slip off side of spool, pull straight off of spool.
- c. Connect the threaded cable plug to the ion chamber hermetic seal connector and slide the push fit cable plug onto the bulkhead feed-thru on the bottom of the center case section.
- d. In order to rest the upper portion of the instrument on a table or the like, slide the cable through the slot in the flange of the cable storage spool and rest the rear of the boot covering the push-fit connector in the semi-circular cut-out in the spool core. See Figure 6. This prevents sharp bends and strains at the point where the cable enters the connector and provides a stable rest for the indicating portion of the instrument.
- e. Place the bottom case section containing the ion chamber upside down at any point within cable reach where it is desired to monitor the radiation environment, such as outside a shelter area. If the cable must pass through any doors or windows, adequate precautions must be taken to prevent crushing, sharp kinking or cutting of the cable. The cable provided with the CD V-717 is the largest which can be stored in the space provided, but it still must be classed as a miniature cable, and as such, is quite vulnerable to damage by unnecessarily rough or careless handling. The threaded cable connector which mates with the ion chamber is designed to resist submersion in one foot of water when mated. The push-on connector at the instrument is resistant to the entry of moisture, but is not intended to be waterproof.
- f. The time required to obtain a satisfactory dose rate indication is considerably increased when using the cable with the remote detector. Allow at least four minutes for the meter to reach a steady value when using the X0.1 range, 50 seconds when on the X1 range, and 9 seconds on the other two ranges.

- g. When reassembling the instrument after remote chamber operation, clean and dry the bottom case section and the chamber. Use decontamination procedures if necessary. Carefully replace the cable on the cable storage spool and store in its allotted space. Be sure the cable is free of dirt, moisture, and/or contamination before rewinding it. The cable must be wound neatly in order to be able to fit it into its storage space. Carefully orient the mating connectors on the two case sections before attempting to close and lock the draw pull catches holding the two case sections together.

NOTE

A certain amount of cleaning may be avoided by placing the case bottom containing the chamber in a thin plastic bag and sealing the neck of the bag around the cable with tape before using. This way, the instrument portion will have been protected from contamination problems when returning it to the shelter, and the cable can merely be rinsed in water and wiped clean, a much simpler operation than trying to deal with a contaminated chamber housing and ion chamber. Avoid wetting the exposed connectors if possible, and if not, dry thoroughly at not over 150°F.

6. OPERATOR'S MAINTENANCE

6.1 BATTERY REPLACEMENT:

Battery replacement is indicated whenever the instrument can no longer be zeroed or when the meter indicates below the "CIRCUIT CHECK" band. To replace the battery, snap open the draw pull catches holding the top case section to the center case section and install a new battery as indicated in paragraph 4.2, BATTERY INSTALLATION. If a battery tester is available the battery may be checked. The battery should be removed from the instrument and stored separately if the instrument is to be stored more than a few weeks.

6.2 CLEANING:

WARNING

Do not use solvents on the plastic parts. To clean, use soap and water. If the battery has leaked, remove the center case section and fill with warm water. The battery spillage will be loosened in a short while and can be rinsed out. Be careful not to soak off the circuit diagram or the CD decal.

Any battery fluids which may run or be washed into the bulkhead feed-thru connector must be completely rinsed out using pure water, after which the feed-thru must be thoroughly dried, preferably by a low temperature bake (150°F).

7. PREVENTIVE MAINTENANCE

7.1 PREVENTIVE MAINTENANCE:

It is recommended that the preventive maintenance procedures be carried out once a month when the instrument is in use, and about once every six months when the instrument is in storage.

Preventive maintenance should be carried out as follows:

- a. Remove the battery, if installed in instrument, clean battery contacts and battery terminals if necessary and remove any corrosion present.
- b. Replace the battery making certain that it makes good contact and exceeds minimum voltage.
- c. Perform the operations indicated in Section 5, Step 1. ZERO ADJUST and Step 2. CIRCUIT CHECK.

The battery should be removed from the instrument and stored separately if the instrument is to be stored more than a few weeks.

8. CORRECTIVE MAINTENANCE

WARNING

Calibration should be attempted only by personnel trained and licensed to use radioactive isotope sources. A "CAL" control setting should not be changed unless prepared to readjust in a radiation field of known intensity.

8.1 CALIBRATION:

The CD V-717 is calibrated by being placed in a gamma radiation field of known dose rate. Such fields are most commonly produced by using a radioactive material such as radium, Cs^{137} , Co^{60} . As an example, a 1 curie radium source will produce a radiation dose of 4 R/hr, at a distance of 18.1 inches. The CD V-717 should read this dose rate when so positioned with the center of the ion chamber at this distance. If it does not, the instrument should be recalibrated. This is accomplished by separating the top and the center case sections and adjusting the individual "CAL" controls for the corresponding ranges so that the proper reading is indicated on the meter (see Figure 7.). The distance from the center of the CD V-717 ionization chamber to the calibrating source should be at least 12 inches to obtain reasonable geometry (reasonably uniform radiation intensity throughout the entire volume of the ionization chamber).

The instrument must be reassembled to see what effect each adjustment has on the instrument reading and to determine if more or less adjustment is required.

8.2 DISASSEMBLY FOR CORRECTIVE MAINTENANCE:

- Release the upper section draw pull catches and remove the instrument top from the center case section.
- Remove the battery from the battery box.
- Remove the knob from the zero control. It is not necessary to remove the selector switch knob.
- Remove the four screws which secure the circuit board assembly to the top case section. Do not lose the ground contact spring. Press on the zero control shaft and lightly pull on the circuit board assembly to release it from the instrument case top section. The

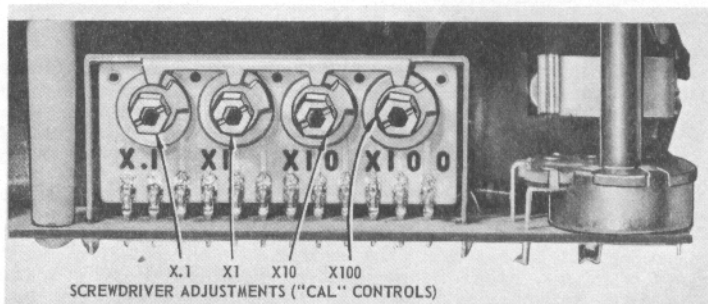

Figure 7. Range Calibration Adjustments

circuit board assembly is now connected to the meter and battery box by four leads, but enough slack is present to allow minor servicing to be done. Care should be taken to insure that leads are not broken by flexing and leads are tucked in so they are not broken in closing the case.

- e. Remove the circuit shield box by removing the two nuts at the top of the box and removing the screw through the circuit board assembly at the sloping end of the shield box. Do not misplace the insulated switch shaft extension.
- f. The entire high impedance circuitry can be removed for servicing or cleaning by removing the two screws holding the resistor support block to the circuit board, removing the two nuts holding the special coated ceramic switch wafer in place, unsoldering the one bare wire lead which goes through the board next to the tube, and unplugging the tube. The tube must be unplugged carefully from its socket to avoid cracking the base or bending the leads excessively. This may be done easily by bending a stiff wire to form a short "L", placing this so it engages the four base leads close to the socket and pulling straight up while lifting the rest of the components by the resistor block. These components should be handled carefully and as little as possible, especially when replacing them after cleaning. Gather up the various washers and spacers, noting their respective positions for proper replacement.
- g. Replacement is the reverse of the disassembly process. Care must be exercised to ensure that the rotors of the two switch wafers are in the correct positions. This should be noted when the unit is disassembled. The tube, resistor block, and ceramic switch wafer assembly is best replaced by first slipping the switch wafer over the two studs (mount the proper washers and spacers first), threading the switch and resistor common connection through the board, and carefully starting the tube leads into the proper socket holes. Needle nose pliers or tweezers are helpful for these operations. Press the tube pins home with one finger, after making sure not to touch the tube base in the process. Start the mounting screws through the circuit board and into the resistor block, but do not draw them up tight. Start the lock nuts on the studs holding the ceramic wafer to the board, and if everything is in proper position, tighten them. Finish tightening the resistor block screws. Solder the resistor and / or switch common lead to the circuit board. Remount the shield box. Install the insulated switch shaft extension. The remainder of the reassembly process is the reverse of the disassembly procedure.

8.3 PRELIMINARY CALIBRATION PROCEDURE AFTER REPLACING THE ELECTROMETER TUBE OR TRANSISTOR:

- a. Turn the instrument on, zero the meter, and check for functioning on "CIRCUIT CHECK."
- b. Move the selector switch through the ranges and observe the stability of the meter indication on the various ranges, particularly X.1.
- c. Using the X.1 range, expose the chamber to radiation and observe the speed of response of the meter. Three possibilities exist:
 - (1) Meter oscillates.
 - (2) Meter responds normally.
 - (3) Meter responds very slowly.

- d. If case (2) occurs, calibrate unit as in 8.1. If (1) or (3) appears, a step adjustment in the feedback loop gain of the electrometer tube—power supply is in order. This is accomplished by shorting out or adding into the active circuit resistors R5 and/or R17.
- e. For case (1), make sure both resistors are in the circuit by removing the solder bridges to ground on the circuit board. See figure below.

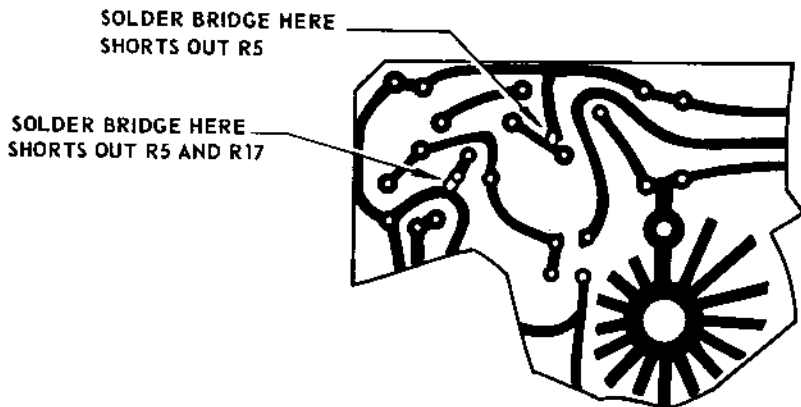

- f. For case (3), short out one or both resistors as needed to increase the speed of response to an acceptable rate.
- g. Calibrate unit as in 8.1.

8.4 TROUBLE SHOOTING:

The majority of the electrical components of the CD V-717 are standard parts familiar to electronic technicians and are readily checked by conventional means. The electrometer tube, the high megohm resistors, the ion chamber insulator and the ceramic switch section are the only components requiring special precaution. These components are all part of the high resistance input circuit. **THE INSULATING PORTIONS OF THESE FOUR COMPONENTS SHOULD NOT BE HANDLED.** They should be touched only with clean tools when repairs are made. If surface leakage on any of these items is suspected, cleaning with clean alcohol using a clean camel hair brush is recommended. Acid core solder should not be used. Avoid solder flux splattering on these components when repairs are made. Dry thoroughly with dry air or in a warm oven.

The battery as well as the measuring circuit are checked by the "CIRCUIT CHECK." If trouble exists, the battery should be checked with a battery tester.

Circuit malfunctions may be traced with the aid of the schematic circuit diagram, Figure 10. Voltage measurements shown on this diagram are measured with respect to point* and are those obtained with a voltmeter having a sensitivity of 20,000 ohms per volt. Such voltage checks should be taken with the instrument selector switch turned to the "ZERO" position and with the zero control adjusted so that the instrument reads zero.

The following troubles and corrective action are presented as an aid to trouble shooting.

TROUBLE SHOOTING CHART

<i>Trouble and Cause</i>	<i>Corrective Action</i>
NO READING	
Battery Low	Replace the Battery
Corroded Battery Contacts	Clean or Replace the Contacts
Meter Damaged	Replace Meter
Chamber Damaged	Replace Chamber
Open Connection	Inspect Solder Joints, Ion Chamber, Cable Connections, Battery and Meter Leads
METER WILL NOT ZERO (Reads Upscale)	
Tube Defective	Replace Tube
Improper Grid Bias or Plate Voltage	Check Tube Operating Voltages, Look For Opens or Shorts On Circuit Board
METER WILL NOT ZERO (Reads Downscale)	
Pegged Downscale With Good Battery	Turn Off Instrument, Turn Zero Full CCW, Turn Instrument On, Bring Zero Slowly CW Until Meter Zeros.
Battery Low	Replace Battery
Defective Tube	Check Tube Filament
Transistor Defective	Replace Transistor
INSTRUMENT READS LOW	
Calibration Control Disturbed	Check Calibration
Defective Tube	Replace Tube
Meter Damaged	Replace Meter
Defective Chamber	Replace Chamber
Dirty High Resistance Components	Clean High Resistance Components
INSTRUMENT READS HIGH	
Calibration Control Disturbed	Check Calibration
Damaged High Megohm Resistor	Replace High Megohm Resistor
Open Switch Contact	Check Switch Contact and Repair or Replace
Dirty High Resistance Components	Clean High Resistance Components
UPSCALE READING ON ONE OR MORE RANGES	
	Dry Out With Heat (150°F) or Less) or Dessicant
NO RESPONSE OR ERRATIC RESPONSE TO RADIATION	
Loss of Contact Between Case Sections	Inspect and Repair All Contacts
Broken Cable	Replace Cable
Poor Cable Connections	Repair Cable Connections

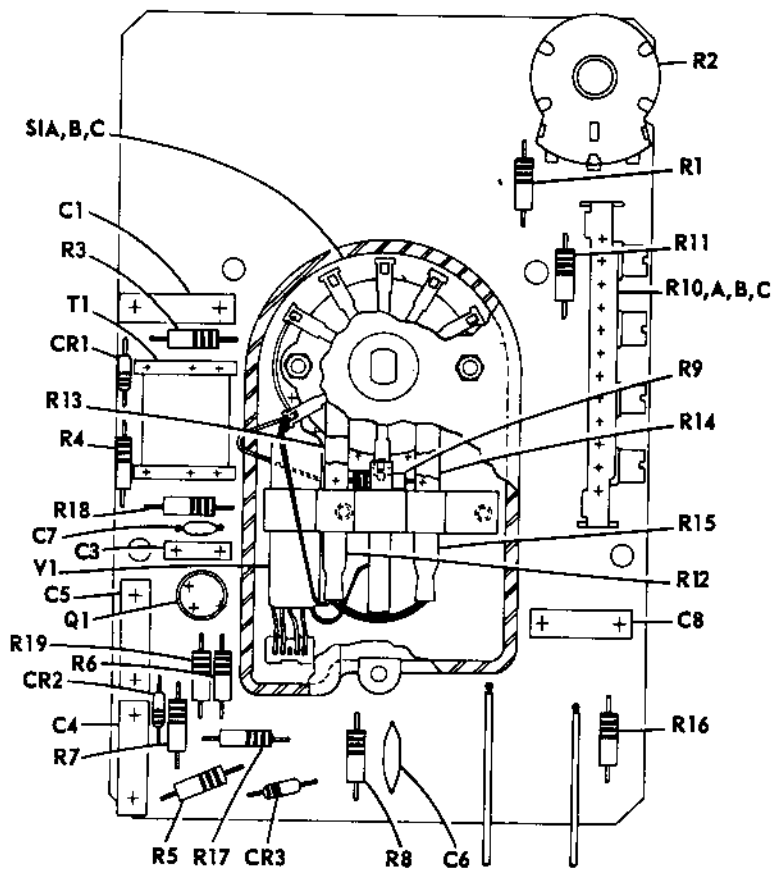

Figure 8. Circuit Board Assembly

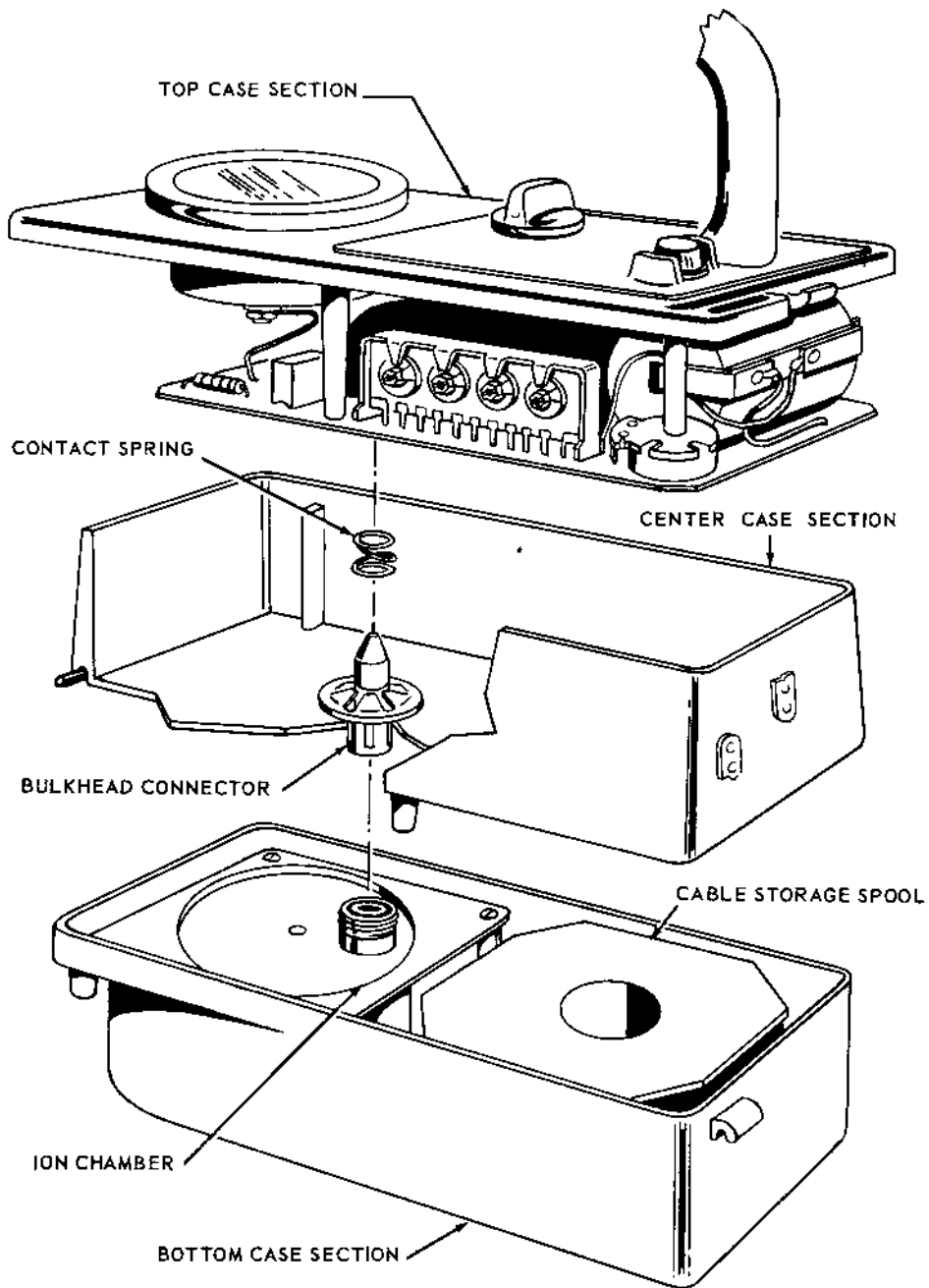
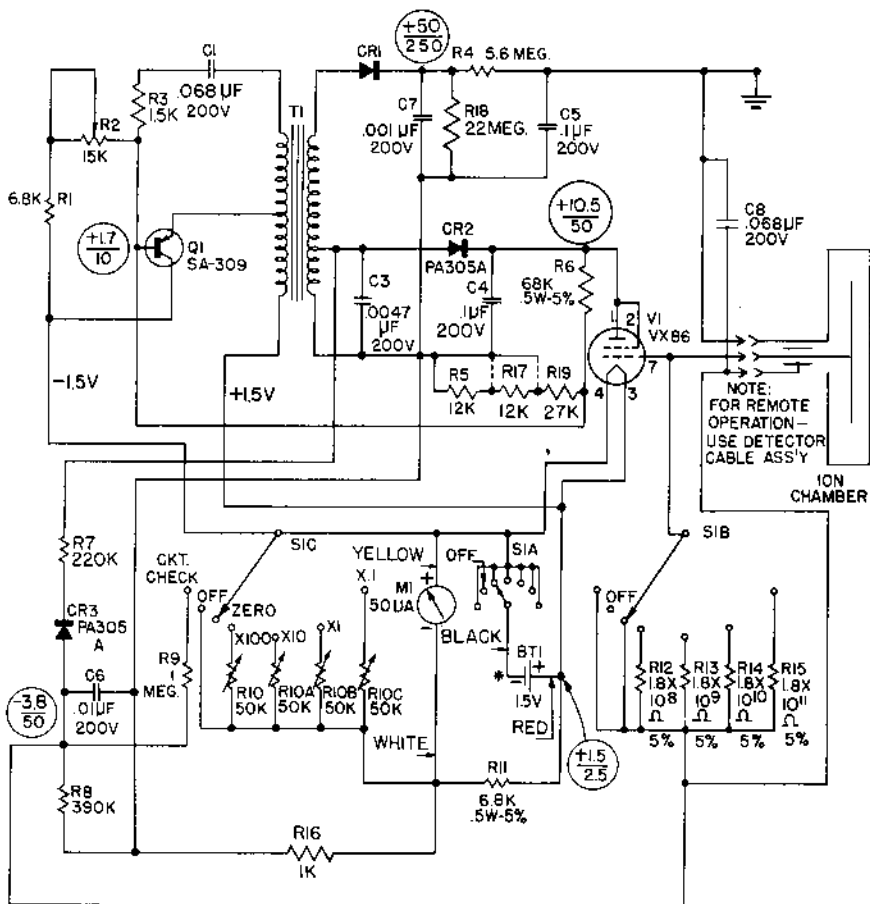

Figure 9. Exploded View



VOLTAGE RANGE VOLTAGES REF TO - BATT. TERM. (*)
INSTRUMENT OPERATING ON ZERO RANGE
WITH ZERO CORRECTLY ADJUSTED.
VOLTAGES MAY VARY $\pm 20\%$ FROM
INSTRUMENT TO INSTRUMENT.

NOTE:
ALL RESISTORS ARE
.5W-10% UNLESS
NOTED OTHERWISE

Figure 10. Schematic Circuit Diagram

9.1 ELECTRICAL COMPONENTS:

Circuit Symbol	Description	Function	Manufacturer	Mfg. Part No.	Victoreen Part No.	Quantity Per Instrument
C1	Capacitor; .068 ufd; 200V	Oscillator Base Coupling Capacitor	John E. Fast	F308C683-3	21-408	2
C3	Capacitor; .0047 ufd; 200V	Oscillator Tank Capacitor	John E. Fast	F308C472-3	21-422	1
C4	Capacitor; .1 ufd; 200V	VX86 Plate Supply Filter Capacitor	John E. Fast	F308C104-3	21-407	2
C5	Same as C4	Chamber Voltage Filter Capacitor				
C6	Capacitor; .01 ufd; 200V	Grid Bias Voltage Filter Capacitor	Radio Materials Co.	SM-.01	21-423	1
C7	Capacitor; .001 ufd; 200V	Chamber Voltage Filter Capacitor	Aerovox Corp.	500282051 0012020	21-424	1
C8	Same as C1	Transient Suppressor Capacitor				
CR1	Diode (Silicon)	Chamber Voltage Supply Rectifier	Raytheon Co.	D59212	52-99	1
CR2	Diode (Silicon)	Plate Voltage Supply Rectifier	Raytheon Co.	D59209	52-100	2
CR3	Same as CR2	Grid Bias Voltage Rectifier				
M1	Meter; 50 ua	Dose Rate Indication	Victoreen	817-18	817-18	1
Q1	Transistor (Germanium)	Power Supply Oscillator	Raytheon Co.	T53750	23-34	1
R1	Resistor; 6.8K; .5W; 10%	Transistor Base Bias Resistor	IRC	GBT-1/2	185-361	2
R2	Potentiometer; 15K; .5W	Zero Adjust Oscillator Base Bias	CTS Corp.	WP-45 Spl.	22-168	1
R3	Resistor; 15K; .5W; 10%	Transistor Base Current Limiter	Stackpole Carbon	RC20	185-351	1
R4	Resistor; 5.6 Meg; .5W; 10%	Decoupling Filter, Chamber Voltage Supply	Stackpole Carbon	RC20	185-406	1
R5	Resistor; 12K; .5W; 10%	Voltage Divider, Oscillator Regulator Circuit	IRC	GBT-1/2	185-368	2
R6	Resistor; 68K; .5W; 5%	Voltage Divider, Oscillator Regulator Circuit	Allen Bradley Co.	EB6835	185-156	1
R7	Resistor; 220K; .5W; 10%	Series Limiter, Grid Bias Supply	Stackpole Carbon	RC20	185-331	1
R8	Resistor; 390K; .5W; 10%	Load Resistor, Grid Bias Supply	Stackpole Carbon	RC20	185-306	1
R9	Resistor; 1 Meg; .5W; 10%	Circuit Check, Shifts Grid Bias	Speer Resistor Co.	RC20	185-1	1
R10	Potentiometer; 50K	Range Cal. Pot.-X100	Centralab	YAN001- 27E6F	22-187	1
R10A	Section of R10; 50K	Range Cal. Pot.-X10				
R10B	Section of R10; 50K	Range Cal. Pot.-X1				
R10C	Section of R10; 50K	Range Cal. Pot.-X0.1				
R11	Same as R1	Zero Signal Bucking Current Limiter				
R12	Resistor; 1.8x10 ⁸ Ohms; 5%	High Megohm Resistor - X100	Victoreen	185-1387	185-1387	1
R13	Resistor; 1.8x10 ⁹ Ohms; 5%	High Megohm Resistor - X10	Victoreen	185-1386	185-1386	1
R14	Resistor; 1.8x10 ¹⁰ Ohms; 5%	High Megohm Resistor - X1	Victoreen	185-1385	185-1385	1
R15	Resistor; 1.8x10 ¹¹ Ohms; 5%	High Megohm Resistor - X0.1	Victoreen	185-1388	185-1388	1
R16	Resistor; 1K; .5W; 10%	Feedback Resistor	IRC	GBT-1/2	185-367	1
R17	Same as R5	Step Gain Adjustment				
R18	Resistor; 22 Meg; .5W; 10%	High Voltage Bleeder	Allen Bradley Co.	EB2261	185-275	1

9.1 ELECTRICAL COMPONENTS (Continued)

Circuit Symbol	Description	Function	Manufacturer	Mfg. Part No.	Victoreen Part No	Quantity Per Instrument
R19	Resistor; 27K; .5W; 10%	Voltage Divider	Allen Bradley Co.	EB2731	185-395	1
S1A	Switch Section; Phenolic Wafer	Battery Switch — ON-OFF	Std. Grigsby Co.	28781-4MLR	817-69	2
S1B	Switch Section; Ceramic Wafer	High Megohm Resistor Selector	Victoreen	817-68	817-68	1
S1C	Switch Section; Phenolic Wafer	Range Cal. Pot. Selector	Std. Grigsby Co.	28781-4MLR	817-69	1
T1	Transformer	Oscillator — Power Supply	Victoreen	14-61	14-61	1
V1	Tube; VX86	Ion Current Detector	Victoreen	35-134	35-134	1
BT1	Battery; 1.5V	d. c. Power Supply to Oscillator and VX86 Filament	Union Carbide Consumers Co.	#950	16-4	1

9.2 MECHANICAL COMPONENTS

Description	Function	Manufacturer	Mfg. Part No.	Victoreen Part No	Quantity Per Instrument
Strap Fastener	Attaches Shoulder Strap	Victoreen	815-47	815-47	2
Shoulder Strap	Carrying Strap	Victoreen	700-81	700-81	1
Strap Buckle	Carrying Strap Length Adjustment	Waterbury Buckle Co.	807 5047	710-44	2
Case Bottom Section	Bottom of Instrument Case	Victoreen	817-6	817-6	1
Knob	Zero Adjust	Harry Davies Molding Co.	1450-AC	9-14	1
Battery Box	Holds Batteries	Victoreen	817-59	817-59	1
Ion Chamber Assembly	Radiation Detector	Victoreen	817-40	817-40	1
"O" Ring	Shaft Seal	Cleveland Ball Bearing Co.	5427-1	46-38	2
Detector Cable Assembly	Remote Detector Operation	Victoreen	817-36	817-36	1
Center Case Section	Circuit Housing	Victoreen	817-7	817-7	1
Switch Drive Shaft	Connects Switch Index to Switch Wafers	Victoreen	817-25	817-25	1
Shield Box	Shields High Impedance Ckt.	Victoreen	817-22	817-22	1
Chamber Terminal Contact	Connects Ion Chamber to Electrometer Tube Circuit	Victoreen	815-19	815-19	1
Tube Socket	Holds Electrometer Tube	Elco Mfg. Corp.	05078852000000	33-49	1
Ckt. Board, Processed	Supports Components	Victoreen	817-61	817-61	1
Knob	Selector Control	Harry Davies Moulding Co.	1500-K	9-9	1
Meter Gasket	Case Top — Meter Seal	Victoreen	817-73	817-73	1
Switch Index	Positions Selector Switch	Victoreen	815-36	815-36	1
Case Top and Handle Assembly	Instrument Carrying Handle and Top of Instrument	Victoreen	817-44	817-44	1

9.2 MECHANICAL COMPONENTS (Continued)

Description	Function	Manufacturer	Mfg. Part No.	Victoreen Part No	Quantity Per Instrument
Case Gasket	Case Top — Case Bottom Seal	Victoreen	720-157	720-157	1
Draw Pull Catches	Holds Case Sections Together	Corbin	15797C	700-74	4
Back Contact Spring	Makes Positive Contact to Battery	Victoreen	817-57	817-57	1
Contact Spring	Makes Negative Contact to Battery	Victoreen	817-10	817-10	1
Lid Spring	Holds Battery Box Closed	Victoreen	817-11	817-11	1
Bulkhead Connector	Makes Contact Between Ion Chamber and High Impedance Circuit	Victoreen	817-53	817-53	1
Contact Spring	Connects Guard Ring to Circuit Board	Victoreen	12-39	12-39	1
Cable Spool	Stores Detector Cable	Victoreen	817-28	817-28	1
Ground Contact Spring	Ground Circuit Board to Case	Victoreen	817-50	817-50	1
Instruction Manual	Operation and Maintenance Manual	Victoreen	817-1	817-1	2

9.3 LIST OF MANUFACTURERS

AEROVOX CORPORATION, Myrtle Beach, South Carolina
 ALLEN BRADLEY COMPANY, 136 West Greenfield Avenue, Milwaukee 4, Wisconsin
 CENTRALAB, INCORPORATED, 900 East Keefe Avenue, Milwaukee, Wisconsin
 CLEVELAND BALL BEARING COMPANY, 2902 Euclid Avenue, Cleveland 15, Ohio
 CORBIN CABINET LOCK DIVISION,
 AMERICAN HARDWARE CORPORATION, New Britain, Connecticut
 CTS CORPORATION, 1142 Beardsley Avenue, Elkhart, Indiana
 ELCO MANUFACTURING CORPORATION, "M" Street, Philadelphia 24, Pennsylvania
 GLOBE UNION, INC., CENTRALAB DIVISION, 900 E. Keefe Street, Milwaukee 1, Wisconsin
 HARRY DAVIES MOULDING COMPANY, 1428 North Wells Street, Chicago 10, Illinois
 INTERNATIONAL RESISTANCE COMPANY, 401 North Broad Street, Philadelphia, Pennsylvania
 JOHN E. FAST DIVISION,
 VICTOREEN INSTRUMENT COMPANY, 3580 Elston Avenue, Chicago, Illinois
 RADIO MATERIALS COMPANY, 4242 West Bryn Marr Avenue, Chicago 46, Illinois
 RAYTHEON MANUFACTURING COMPANY,
 SEMICONDUCTOR DIVISION, 350 Ellis Street, Mountain View, California
 SPEER CARBON COMPANY, SPEER RESISTOR DIVISION, St. Marys, Pennsylvania
 STACKPOLE CARBON COMPANY, St. Marys, Pennsylvania
 STANDARD GRIGSBY, INC., 2085 North Hawthorne Avenue, Melrose Park, Illinois
 UNION CARBIDE CORPORATION,
 CONSUMER'S PRODUCTS DIVISION, 875 Green Tree Road, Parkway Center, Pittsburgh, Pennsylvania
 VICTOREEN INSTRUMENT COMPANY, 5806 Hough Avenue, Cleveland 3, Ohio
 WATERBURY BUCKLE COMPANY, 862 South Main Street, Waterbury 20, Connecticut